

**KOMATSU**  
Utility Corporation



**KOMATSU**

Machine Shown with  
Optional Equipment



## **PC12R-8 COMPACT EXCAVATOR**

### **FEATURING**

- HydraMind System
- Swing Boom
- Rubber Tracks
- Proportional Pressure Controlled (PPC) Joysticks

## Engine

Model ..... Komatsu 3D68E-3G  
 Flywheel Horsepower  
 (SAEJ1349) ..... 13.8 HP/10.3 kW@2450 rpm  
 (DIN6271NET) ..... 14.0 PS/10.3 kW@2450 rpm  
 Displacement ..... 47.8 cu. in. 0.78 ltr.

## Hydraulic System

Type ..... HydraMind  
 Pump Type ..... 3xGear  
 System Operating Pressure ..... 2715 psi 190 kg/cm<sup>2</sup>  
 Auxiliary Hydraulic Flow ..... 6.6 gpm 25.0 l/min.

## Swing System

Boom Swing Angle (L/R) ..... 90/50  
 Swing Speed ..... 8.7 rpm

## Drive and Brakes

Travel Speed ..... 1.3/2.5 mph 2.1/4.0 km/h  
 Service Brake ..... Hydraulic Locking  
 Parking Brake ..... N/A

## Undercarriage

No. of Carrier Rollers ..... N/A  
 No. of Track Rollers ..... 3  
 Ground Pressure ..... 4.1 psi 0.28 kg/cm<sup>2</sup>

## Coolant and Lubricant

Fuel Tank ..... 5.3 US gal. 20.0 ltr.  
 Coolant ..... 0.7 US gal. 2.8 ltr.  
 Engine Oil ..... 0.8 US gal. 3.0 ltr.  
 Hydraulic Tank ..... 3.4 US gal. 12.9 ltr.

## Standard Equipment

- Front blade
- Rubber tracks
- TOPS canopy

## Optional Equipment

- Auxiliary hydraulic piping
- Long arm
- Steel tracks

## Dimensions & Weights

Operating Weight	3,060 lb.	1390 kg
A. Overall Length	11'6"	3505 mm
B. Overall Width	3'3"	990 mm
C. Overall Height	7'5"	2260 mm
D. Min. Ground Clearance	8"	200 mm
E. Tail Swing Radius	3'6"	1065 mm
F. Track Width	8"	200 mm

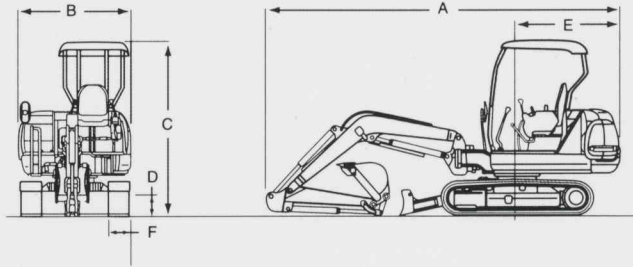

## Working Range

A. Max. Digging Depth	6'3"	1905 mm
B. Max. Dumping Height	7'8"	2335 mm
C. Max. Digging Height	11'0"	3350 mm
D. Max. Vertical Digging Depth	4'11"	1500 mm
E. Max. Digging Reach at Ground	11'3"	3430 mm
F. Max. Digging Reach	11'6"	3505 mm
Bucket Breakout Force	2,900 lb.	1315 kg

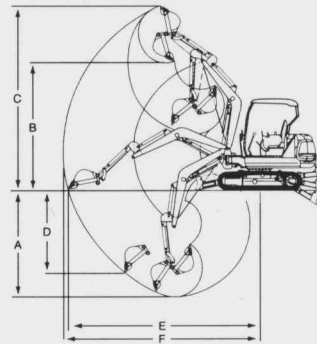

## Bucket & Arm Combinations

O General purpose use, weight up to 3040 lbs./cu.yd.  
 Δ Material weight up to 2020 lbs./cu.yd.  
 X Not available

Model	SAE Heaped Capacity	Bucket Width		Weight		Standard Bucket	Arm Selection			
							Standard		Long	
PC12R-8	0.8 cu. ft. .022 m <sup>3</sup>	12"	300 mm	46 lbs.	21 kg.			O		O
	1.4 cu. ft. .039 m <sup>3</sup>	16"	400 mm	55 lbs.	25 kg.	O	2'11" (890 mm)	O	3'8" (1120 mm)	X
	1.6 cu. ft. .045 m <sup>3</sup>	18"	460 mm	60 lbs.	27 kg.			Δ		X

This specification sheet may contain attachments and optional equipment that are not available in your area. Please contact your local Komatsu Utility Corporation distributor for those items you may require. Materials and specifications are subject to change without notice.

**KOMATSU** *Utility*  
 Utility Corporation  
 PO Box 8112 • Vernon Hills, IL 60061-8112  
 website: www.komatsuutility.com