

# KOMATSU®

## HD785-7

**GROSS HORSEPOWER**

895 kW **1,200 HP**

**NET HORSEPOWER**

879 kW **1,178 HP**

**MAXIMUM GVW**

166000 kg **366,000 lb**

**HD**  
**785**

OFF-HIGHWAY TRUCK



Photos may include optional equipment

# WALK-AROUND

## *Productivity and Economy Features*

- High performance Komatsu SAA12V140E-3 engine  
Net horsepower 879 kW **1,178 HP**
- Mode selection system with Variable HorsePower Control (VHPC)
- Two-speed selective reverse gears, RH and RL
- Anti-pitching 4-wheel oil-cooled multiple-disc retarder (AP-FOUR)  
Retarder absorbing capacity 1092 kW **1,464 HP**  
(continuous descent)
- Automatic Retard Speed Control (ARSC) standard

## *Harmony with Environment*

- Komatsu SAA12V140E-3 engine meets  
EPA Tier 2 emissions regulations
- Lead-free radiator
- Low operation noise
- Low fuel consumption

## *Reliability Features*

- Flat face-to-face O-ring seals
- Sealed DT connectors



### ***Operator Environment and Control***

- Spacious cab with excellent visibility
- Ergonomically designed cab
- Easy-to-see instrument panel
- Synchronous control of engine and transmission
- Advanced K-ATOMiCS with “Skip-shift” function
- Viscous cab mounts
- Electric body dump control
- Built-in ROPS/FOPS, Level 2 cab
- Parking brakes on 4-wheels
- Supplemental steering
- Pedal-operated secondary brake
- Three-mode automatic hydropneumatic suspension (optional)

#### **GROSS HORSEPOWER**

895 kW 1,200 HP @ 1900 rpm

#### **NET HORSEPOWER**

879 kW 1,178 HP @ 1900 rpm

#### **MAXIMUM GVW**

166000 kg **366,000 lb**



### ***Easy Maintenance***

- Oil-cooled multiple-disc brakes and fully hydraulic-controlled braking system
- Extended oil change interval
- Disc wheels (flange type rims)
- Electric circuit breakers
- KOMTRAX Plus

# PRODUCTIVITY & ECONOMY FEATURES

## High Performance Komatsu SAA12V140E-3 Engine

This engine delivers faster acceleration and higher travel speeds with high horsepower per ton. Advanced technology, such as High Pressure Common Rail (HPCR) injection system and an efficient air-to-air aftercooler turbo-charger enables the engine to meet EPA Tier 2 emissions regulations. High torque at low speed, impressive acceleration, and low fuel consumption ensure maximum productivity.

## Mode Selection System with VHPC

The system allows selection of the appropriate mode, <Power mode> or <Economy mode>, according to the working condition. The mode is easily selected with a switch in the operator's cab. When the key switch is turned on, Economy mode is selected automatically. Select Power mode when needed by using a switch on the dash.

## Variable HorsePower Control (VHPC)

Both in Power and Economy modes, the VHPC system detects whether the truck is loaded or not loaded and selects the optimum horsepower setting mode, providing both high production and low fuel consumption.

- **Power mode:** Makes the best use of horsepower to attain optimal production. This mode is suitable for operation in job sites including uphill travel with a load where throughput takes top priority.
- **Economy mode:** Sets the maximum horsepower at a lower level to reduce fuel consumption. The machine maintains sufficient power for normal operation in this mode.

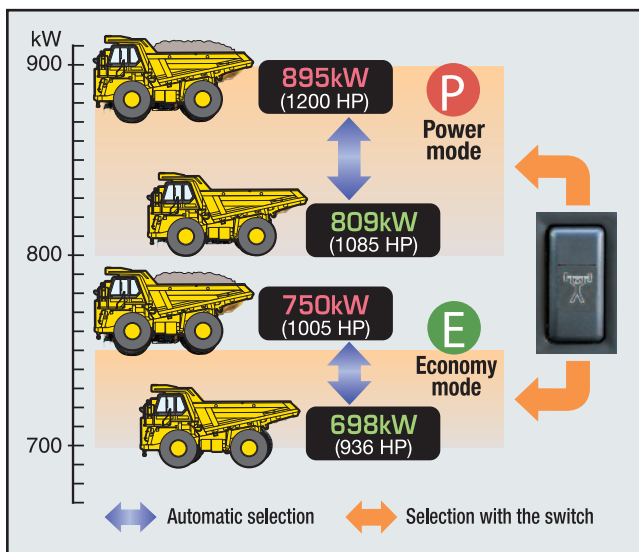

Photos may include optional equipment.

## F7-R2 (RH/RL) Fully Automatic Transmission

The transmission is configured with 7 forward and 2 reverse gears. Fully automatic control is applied to all forward gears and an optimum gear is automatically selected according to the travel speed and engine speed. To reduce fuel consumption, the shifting point is automatically selected depending on the acceleration of the machine.



## Two-Speed Selective Reverse Gears (RH/RL)

In order to meet various operating conditions, two reverse gears are provided. By a setting found in the Electronic Machine Monitoring System (EMMS), an operator can select the appropriate gear for the application, RH or RL. Furthermore, the reverse gear is equipped with a lockup clutch, just like the forward gears, allowing the operator to reverse the machine without concern of overheating.

### RH

Suitable for normal operation. With the lockup clutch, the machine can be reversed at higher speed than the current model while obtaining the same rimpull.

### RL

Suitable for operation in job sites where there are steep grades.

**AP-FOUR (Anti-Pitching 4-wheel Oil-Cooled Multiple Disc Retarder)**

The HD785-7 is equipped with AP-FOUR that applies retarding force on all four wheels. This reduces the possibility of tire-lock and enables effective use of retarder capacity, allowing stable downhill travel. The machine descends slopes smoothly and comfortably without machine body pitching since retarding force on the front and rear wheels is controlled independently.

- Retarder absorbing capacity  
1092 kW **1,464 HP** (continuous descent)
- Brake surface area  
Front total : 37467 cm<sup>2</sup> **5,807 in<sup>2</sup>**  
Rear total : 72414 cm<sup>2</sup> **11,224 in<sup>2</sup>**

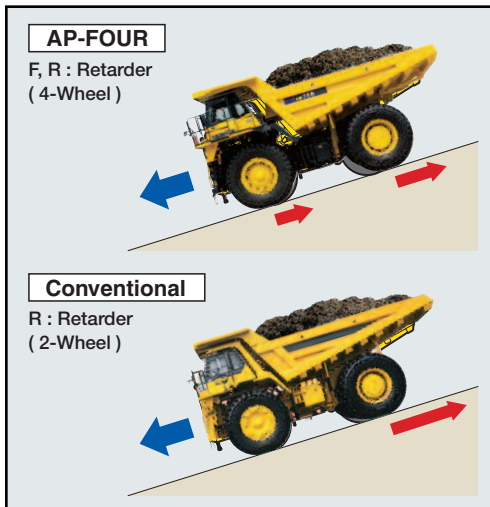

**Auto Retard Speed Control (ARSC)**

ARSC allows the operator to simply set the downhill travel speed and descend grades at a constant speed. This allows the operator to concentrate on steering. The speed can be set at increments of 1 km/h **0.6 MPH** per click ( $\pm 5$  km/h **3.1 MPH** of setting speed adjustment) to match the optimum speed for the slope. The retarder cooling oil temperature is constantly monitored and the descent speed is automatically reduced, if necessary.



Photos may include optional equipment.

# HD785-7 OFF-HIGHWAY TRUCK

## Automatic Idling Setting System (AISS)

This system facilitates quick engine warm-up and cab cooling/warming. When setting the system ON, engine idle speed is kept at 945 rpm when coolant temperature is 50°C **122°F** or lower. Speed automatically returns to 750 rpm when coolant temperature goes above 50°C **122°F**.



## Small Turning Radius

The MacPherson strut type front suspension has a special A-frame between each wheel and the main frame. The wider space created between the front wheels and the main frame increases the turning angle of the wheels. The larger this turning angle, the smaller the turning radius of the truck.

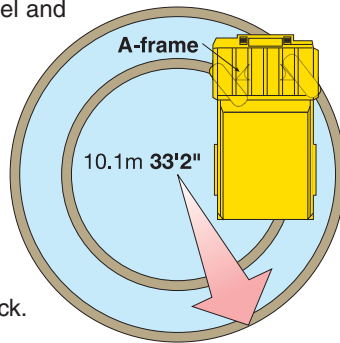

Photos may include optional equipment.

## Long Wheelbase and Wide Tread

With an extra-long wheelbase, a wide tread, and an exceptionally low center of gravity, the HD785-7 hauls its load at higher speed for greater productivity, and delivers superior driving comfort over rough terrain.

## Large Body

A wide target area makes for easy loading with minimal spillage and more efficient hauling.

Heaped capacity : 60.0 m<sup>3</sup> **78.5 yd<sup>3</sup>**

Target area (inside length x width) :

7065 mm **23' 2"** x 5200 mm **17' 1"**



Photos may include optional equipment.

# OPERATOR ENVIRONMENT

## Spacious Cab with Excellent Visibility

Wide windows in the front, side and back, plus plenty of space in the richly upholstered interior, provide a quiet, comfortable environment for better visibility and control over every aspect of operation. Front underview mirrors and rear view camera have been added to improve visibility.

## Ergonomically Designed Cab

The comfortable and ergonomically designed operator's compartment makes it very easy for the operator to reach all controls resulting in greater productivity.

## Easy-to-See Instrument Panel

The instrument panel makes it easy to monitor critical machine functions. In addition, a caution light warns the operator of any issues that may occur. Problems are recorded in the monitor and indicated as service codes. This makes the machine more user friendly and easier to service.



## Ideal Driving Position Settings

The 5-way adjustable operator seat and the tilt-telescopic steering column provide an optimum driving posture for increased driving comfort and more control over machine operation. The suspension seat dampens vibrations transmitted from the machine and reduces operator fatigue. A 78 mm 3" wide seat belt is provided as standard equipment.



Photos may include optional equipment

# HD785-7 OFF-HIGHWAY TRUCK

## Synchronous Control of Engine and Transmission

During gear shifting, the engine speed is controlled to coincide with transmission rotation speed which reduces shifting shocks. The synchronous control improves the durability of the power train by reducing torque fluctuation.

## Advanced K-ATOMiCS

The electronically controlled all clutch modulation system, “K-ATOMiCS”, optimizes the clutch engagement oil pressure at every gear. This system optimizes the clutch lock-up process for smoother shifting with minimal torque shock.

## “Skip-shift” function

When driving uphill, the skip-shift function automatically selects the gear according to the slope of the grade. It reduces the number of down-shifts, makes the driving smoother, improves operator comfort, and reduces spilling of material.

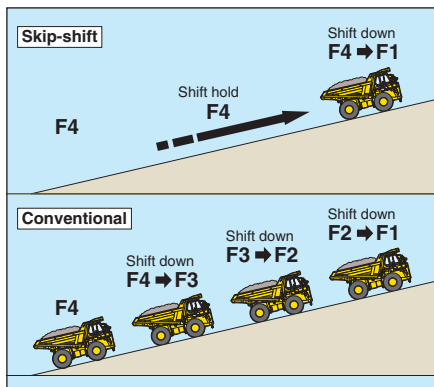

## The MacPherson Strut-Type Front Suspension

The MacPherson-type independent suspension is utilized on the front wheels. This linkage arrangement allows the front wheel to follow the undulation of the road surface smoothly, realizing excellent riding comfort.

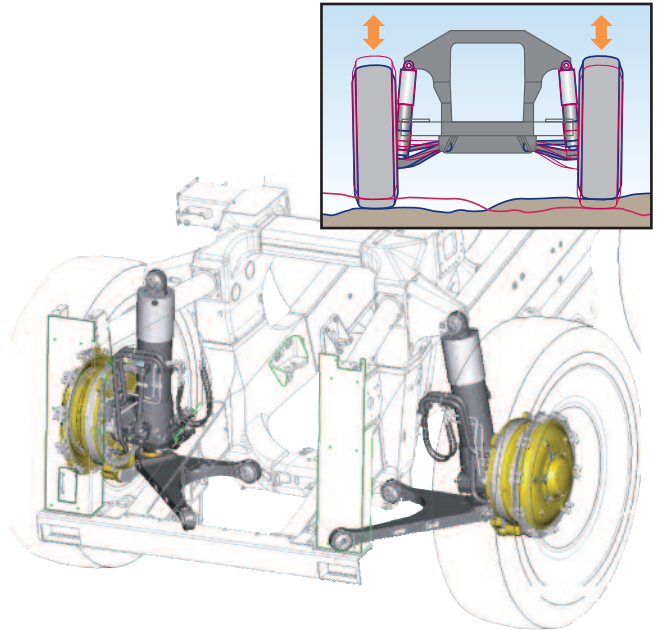

## Three-Mode Automatic Hydropneumatic Suspension (Option)

Suspension mode is automatically switched to one of three stages (soft, medium and hard) according to the load and operating conditions, for a more comfortable and stable ride.



Photos may include optional equipment.



**Viscous Cab Mounts**

Large capacity viscous cab mounts with excellent damping performance are used to mount the cab. They reduce cab vibration significantly and provide a comfortable cab environment with superb quietness and less vibration. Noise level at operator's ear is 75 dB(A).

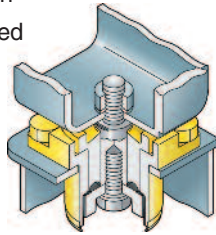

**Integral Four-Post ROPS/FOPS Level 2 Cab Structure**



**Parking Brakes on 4-Wheels**

The HD785-7 is equipped with spring applied parking brakes on all 4-wheels. Wet multiple disc brakes, built in both front and rear axles, apply braking force to all four wheels. The brakes require minimal periodic maintenance.

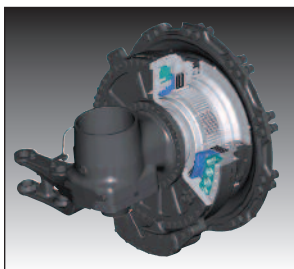

Front brake

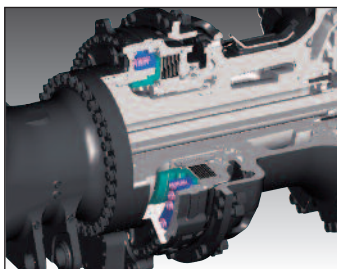

Rear brake

**Supplemental Steering**

Automatic supplemental steering is provided as a standard feature.

**Electric Body Dump Control**

An electric lever is used for body dump control. The lever is short in control travel and can be operated with light hand effort. The "kick-out function" facilitates body dump operation, eliminating the need to hold the lever in dump position.

Furthermore, body seating shock is significantly reduced because a sensor detects the body just before reaching the seat and reduces speed of decent.



**Pedal-Operated Secondary Brake**

Both front and rear parking brakes are activated as a pedal operated secondary brake. In addition, when hydraulic pressure drops below the rated level, the parking brake is automatically actuated.



**Antilock Braking System (ABS) (optional)**

Using its outstanding electronics technology, Komatsu is the first in the industry to introduce ABS on construction machinery. This system prevents the tires from locking, thus helps limit skidding under slippery conditions while applying the service brake.

**Automatic Spin Regulator (ASR) (optional)**

ASR automatically maximizes traction by preventing the rear tires from slipping on either side.



Photos may include optional equipment.

# DASH-7 FEATURES

## Komatsu Components

Komatsu manufactures the engine, torque converter, transmission, hydraulic units, and electrical parts on this dump truck. Komatsu dump trucks are manufactured with an integrated production system under strict quality control system guidelines.

## High-Rigidity Frame

Front support is integrated with the frame. The frame rigidity has been substantially increased. As a result, flexural rigidity and torsional rigidity, which are indicators of drivability and ride quality, are significantly improved.



## Rugged and Durable Dump Body Design

The standard dump body is made of high-tensile-strength steel with a Brinell hardness of 400 for excellent rigidity and reduced maintenance cost. The V-shape and V-bottom design also increase structural strength. The side and bottom plates of the dump section are reinforced with ribs for added strength.



## Reliable Hydraulic System

A large capacity oil cooler is installed in each hydraulic circuit, improving the reliability of the hydraulic units during sudden temperature rises. Further, in addition to the main filter, a  $\beta_{10} = 3$  (min) line filter is located at the entrance to the transmission control valve. This system helps prevent secondary faults.

## Flat Face-to-Face O-Ring Seals

Flat face-to-face O-ring seals are used to securely seal all hydraulic hose connections and to prevent oil leakage.

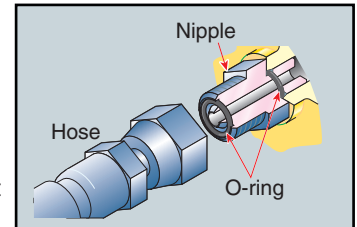

## Sealed DT Connectors

Main harnesses and controller connectors are equipped with sealed DT connectors providing high reliability, water resistance, and dust resistance.



## Protection Function Supported by Electronic Control

Item	Function
<b>Downshift inhibitor</b>	Even if the driver downshifts accidentally, a speed appropriate to the current gear is automatically set, limiting potential over-runs.
<b>Over-run inhibitor</b>	When descending grades, if the vehicle's speed surpasses the maximum for the current gear, the rear brakes automatically operate, limiting potential over-runs.
<b>Reverse inhibitor</b>	The vehicle is prevented from moving backward when operating the body.
<b>Forward/Reverse shift inhibitor</b>	This device makes it impossible to shift from forward to reverse when the vehicle's speed surpasses 4km/hr 2.5 mph.
<b>Anti-hunting system</b>	When running near a shift point, smooth automatic shifting takes place.
<b>Neutral safety</b>	The engine is prevented from starting when the shift lever is not in neutral.

## Ecology

### Lead-Free Radiator

In addition to compliance with emission regulations, a lead-free aluminum core is used for the radiator to meet global environmental requirements.

### Brake Cooling Oil Recovery Tank

To protect the environment, a tank is installed to recover brake cooling oil in the event of brake floating seal leakage.



# OPERATOR STATION

## Advanced Monitoring System

The Komatsu advanced monitoring system identifies maintenance items, reduces diagnostic times, indicates oil and filter replacement hours and displays abnormality codes. This monitor system helps to maximize machine production time.



**Wet multi-disc brakes and fully hydraulic controlled braking systems** realize lower maintenance costs and higher reliability. Wet disc brakes are fully sealed to keep contaminants out, reducing wear and maintenance. Brakes require no adjustments for wear, meaning even lower maintenance. The parking brake is also an adjustment-free, wet multiple-disc system for high reliability and long life. Added reliability is designed into the braking system by the use of three independent hydraulic circuits providing hydraulic backup. Fully hydraulic braking systems eliminate the air system; air bleeding is not required, and water condensation that can lead to contamination, corrosion and freezing is eliminated.

## Extended Oil Change Intervals

In order to minimize operating costs, oil change intervals have been extended:

- Engine oil 500 hours
- Hydraulic oil 4000 hours

## Centralized Arrangement of Filters

The filters are centralized so that they can be easily serviced.



## Disc Wheels (flange-type rims)

Disc wheels (flange-type rims) allow for easy removal and installation of tires.



## Electric Circuit Breaker

A circuit breaker is adopted for important electric circuits which need to be restored quickly when a problem occurs in the electrical system.



## Centralized Greasing Points

Greasing points are centralized at three locations enabling ground level servicing.



## KOMTRAX Plus

As part of a complete service and support program, Komatsu equips every mining and quarry sized machine with KOMTRAX Plus. By using a satellite-based communication system, KOMTRAX Plus offers a new vision of monitoring your valuable assets by providing insight to critical operating metrics and information that can be used to increase availability, lower owning and operating costs and maximize fuel efficiency.

The KOMTRAX Plus information available on MyKomatsu.com allows service personnel and asset owners to review cautions, operational data, fuel consumption, payloads and key component measurements provided in forms of trends. With KOMTRAX Plus, knowledge becomes the power to fuel your productivity.



## Payload Meter (PLM)

PLM allows the production volume and working conditions on the dump truck to be analyzed and controlled directly via a personal computer. The payload is indicated both in the operator's cab and with a lamp on the outside of the truck. The system can store up to 2900 working cycles.

# SPECIFICATIONS



## ENGINE

Model	Komatsu SAA12V140E-3
Type	Water-cooled, 4-cycle
Aspiration	Turbo-charged, after-cooled
Number of cylinders	12
Bore x Stroke	140 mm x 165 mm <b>5.51" x 6.50"</b>
Piston displacement	30.48 ltr <b>1,860 in<sup>3</sup></b>
Horsepower	
SAE J1995	Gross 895 kW <b>1,200 HP</b>
ISO 9249 / SAE J1349	Net 879 kW <b>1,178 HP</b>
Rated rpm	1,900 rpm
Fan drive type	Mechanical
Maximum torque	518 kg•m <b>3,747 lb ft</b>
Fuel system	Direct injection
Governor	Electronic control
Lubrication system	
Method	Gear pump, force-lubrication
Filter	Full-flow type
Air cleaner	Dry type with double elements and pre-cleaned, with dust indicator



## TRANSMISSION

Torque converter	3-elements, 1-stage, 2-phase
Transmission	Full-automatic, planetary-shaft type
Speed range	7 speeds forward and 2 reverse (RH, RL)
Lockup clutch	Wet, multiple-disc clutch
Forward	Torque converter drive in 1st gear, direct drive in 1st lockup and all higher gears
Reverse	Torque converter drive, direct drive (lockup)
Shift control	Electronic shift control with automatic clutch modulation in all gear
Maximum travel speed	65 km/h <b>40.4 mph</b>



## AXLES

Rear axles	Full-floating
Final drive type	Planetary gear
Ratios:	
Differential	3.357
Planetary	6.333



## SUSPENSION SYSTEM

Independent, hydropneumatic suspension cylinder with fixed throttle to dampen vibration.	
Effective cylinder stroke:	
Front suspension	320 mm <b>12.6"</b>
Rear suspension	127 mm <b>5.0"</b>
Rear axle oscillation	6.5°



## STEERING SYSTEM

Type	Fully hydraulic power steering with two double-acting cylinders,
Supplemental steering	Electro-hydraulic motor
Minimum turning radius	10.1 m <b>33'2"</b>
Maximum steering angle	41°



## CAB

Integral four-post ROPS/FOPS Level 2 cab structure



## MAIN FRAME

Type	Box-sectioned structure Integral front bumper
------	--



## BRAKES

Brakes meet ISO 3450 standard.

Service brakes:

Front	Fully hydraulic control, oil-cooled multiple-disc type
Rear	Fully hydraulic control, oil-cooled multiple-disc type
Parking brake	Spring applied, multiple-disc type (actuates on all wheels)
Retarder	Oil-cooled, multiple-disc front and rear brakes act as retarder.
Secondary brake	Manual pedal operation.
	When hydraulic pressure drops below the rated level, parking brake is automatically actuated.

Brake surface

Front	37467 cm <sup>2</sup> <b>5,807 in<sup>2</sup></b>
Rear	72414 cm <sup>2</sup> <b>11,224 in<sup>2</sup></b>



## BODY

Capacity:

Struck	40 m <sup>3</sup> <b>52.3 yd<sup>3</sup></b>
Heaped (2:1, SAE)	60 m <sup>3</sup> <b>78.5 yd<sup>3</sup></b>
Payload	91.0 metric tons <b>100.3 U.S. tons</b>
Material	400 Brinell hardness high tensile strength steel
Structure	V-shape body with V-bottom
Material thickness:	
Bottom	19 mm <b>0.75"</b>
Front	12 mm <b>0.47"</b>
Sides	9 mm <b>0.35"</b>
Target area (inside length x width)	7065 mm x 5200 mm <b>23'2" x 17'1"</b>
Dumping angle	48°
Height at full dump	10080 mm <b>33'1"</b>
Heating	Exhaust heating



## HYDRAULIC SYSTEM

Hoist cylinder	Twin, 2-stage telescopic type
Relief pressure	20.6 MPa 210 kg/cm <sup>2</sup> <b>2,990 psi</b>
Hoist time	
Raise	13 sec
Lower	14 sec



## WEIGHT (APPROXIMATE)

Empty weight	72000 kg <b>158,800 lb</b>
Max. gross vehicle weight	166000 kg <b>366,000 lb</b>
Not to exceed max. gross vehicle weight, including options, fuel and payload.	
Weight distribution:	
Empty: Front axle	47%
Rear axle	53%
Loaded: Front axle	31.5%
Rear axle	68.5%



## TIRES

Standard tire	27.00 R49
---------------	-----------



## SERVICE REFILL CAPACITIES

Fuel tank	1308 ltr. <b>345.6 U.S. Gal</b>
Engine oil	129 ltr. <b>34.1 U.S. Gal</b>
Torque converter, transmission and retarder cooling	205 ltr. <b>54.2 U.S. Gal</b>
Differentials	137 ltr. <b>36.2 U.S. Gal</b>
Final drives (total)	128 ltr. <b>33.8 U.S. Gal</b>
Hydraulic system	175 ltr. <b>46.2 U.S. Gal</b>
Brake control	36 ltr. <b>9.5 U.S. Gal</b>
Suspension (total)	93 ltr. <b>24.6 U.S. Gal</b>
Engine coolant	283 ltr. <b>74.8 U.S. Gal</b>



## DIMENSIONS

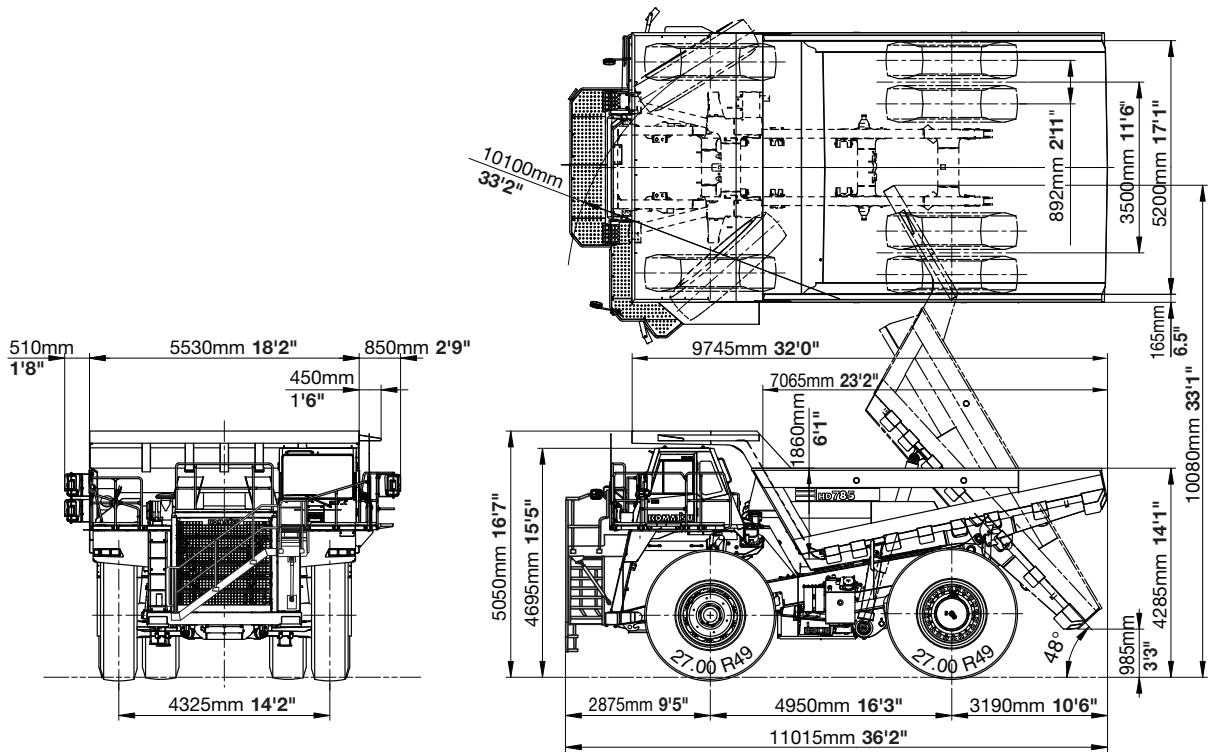

## TRAVEL PERFORMANCE

To determine travel performance: Read from gross weight down to the percent of total resistance. From this weight-resistance point, read horizontally to the curve with the highest obtainable speed range, then down to maximum speed. Usable rimpull depends upon traction available and weight on drive wheels.

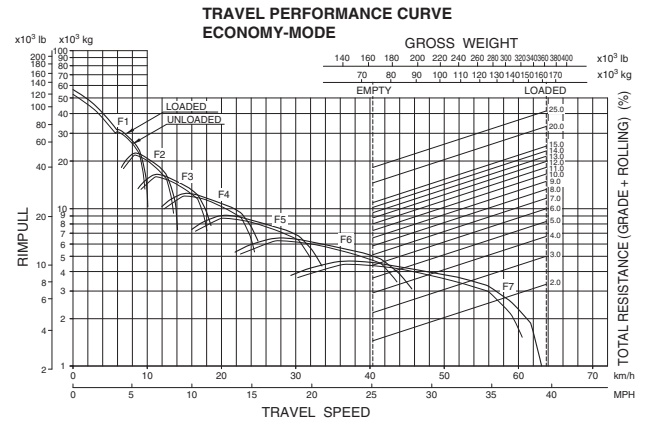
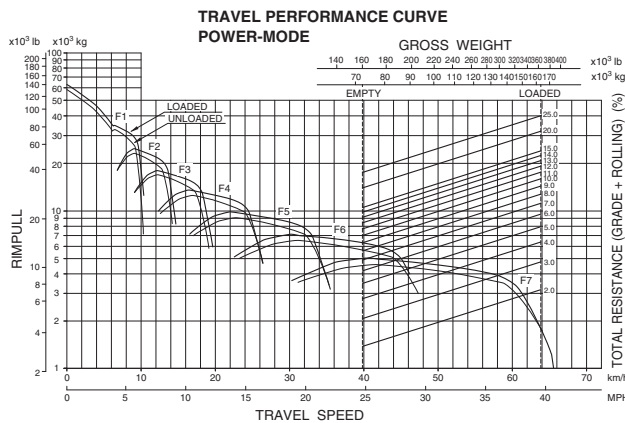

## BRAKE PERFORMANCE

To determine brake performance: These curves are provided to establish the maximum speed and gearshift position for descents on roads with a given distance. Read from gross weight down to the percent of total resistance. From this weight resistance point, read horizontally to the curve with the highest obtainable speed range, then down to maximum descent speed the brakes can safely handle without exceeding cooling capacity.

### Grade Distance: Continuous Descent

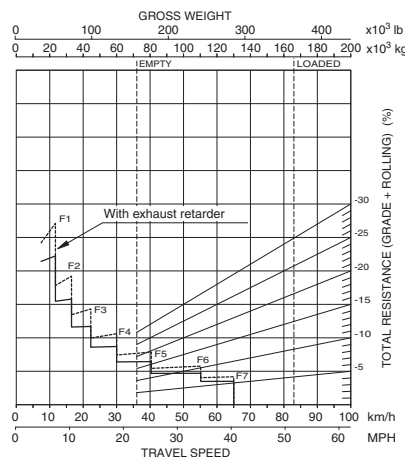

### Grade Distance: 450 m (1,480 ft)

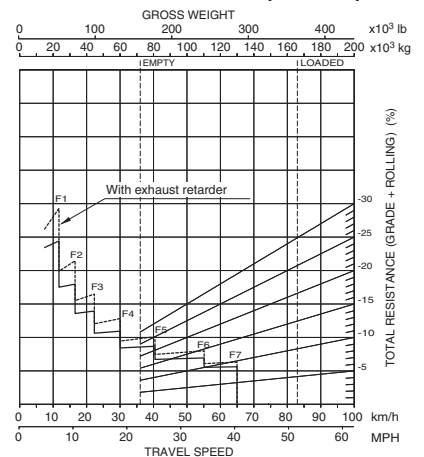



## STANDARD EQUIPMENT FOR BASE MACHINE

### ENGINE

- Automatic Idling Setting System (AISS)
- Alternator, 90A/24V
- Batteries, 4 x 12V/170Ah
- Engine pre-lube system
- Komatsu SAA12V140E-3 engine meets EPA Tier 2 emissions regulations
- Mode selection system with VHPC
- Starting motor, 2 x 7.5 kW

### CAB

- Air conditioner
- Ashtray
- Cigarette lighter
- Cup holder
- Electronic dump control system with body positioner
- Electronic maintenance display/monitoring system
- Glass, tempered, sides and back
- Heater and defroster
- Integral ROPS/FOPS Cab Level 2
- Laminated glass, front
- Operator seat, reclining, air suspension type with retractable 78 mm 3" width seat belt
- Passenger seat with retractable 78 mm 3" width seat belt
- Power windows (LH & RH)
- Radio, AM/FM with cassette
- Space for lunch box

- Steering wheel, tilt and telescopic
- Sun visor (2)
- Two doors, left and right
- Windshield washer and wiper (with intermittent feature)

### LIGHTING SYSTEM

- Back-up light
- Hazard lights
- Headlights, HID low
- Indicator, stop and tail lights (LED type)

### COVERS

- Exhaust thermal covers

### OPERATOR ENVIRONMENT AND CONTROL

- Alarm, backup
- Anti-pitching 4-wheel oil-cooled multiple disc retarder (AP-FOUR)
- Automatic Retard Speed Control (ARSC)
- Automatic supplemental steering
- Coolant temperature alarm and light
- Exhaust retarder
- Guardrails for platforms
- Horn, electric
- Overspeed warning system
- Rearview and underview mirrors (left & right side)
- Rearview camera and monitor
- Tire stopper blocks

### BODY

- Body exhaust heating
- Cab guard, left side
- Platform guard, right hand side
- Spill guard, 150 mm 6"

### OTHER

- Centralized greasing
- Diagonal stairway
- Disc wheels (Flange type rims)
- Drive shaft guard (front and rear)
- Electric circuit breaker, 24V
- Engine underguard
- Fire extinguisher
- Ground level fast fuel fill
- Komtrax Plus
- Ladder, right hand side
- Mud guards
- Payload meter
- Tool kit
- Transmission underguard
- Vandalism protection



## OPTIONAL EQUIPMENT

### BODY

- Body liners

### LIGHTING SYSTEM

- Fog lights
- HID side working lights

### TIRES

- 27.00 R49

### OPERATOR ENVIRONMENT AND CONTROL

- Antilock Brake System (ABS)
- Automatic Spin Regulator (ASR)

### ARRANGEMENT

- Batteries for cold area arrangement
- Cold area arrangement, -30°C
- Hot area arrangement, 50°C

### OTHER

- Engine coolant heater
- Engine oil pan heater
- Engine side covers
- Ground level coolant fast fill
- Ground level oil fast fill
- Mufflers, deck mounted
- Three-mode hydropneumatic suspension

Standard equipment may vary for each country, and this specification sheet may contain attachments and optional equipment that are not available in your area. Please consult your Komatsu Distributor for detailed information.

