

Engine 3TNV76

Engine power 14,0 kW - 19,0 HP

Operating Weight 2.160 - 2.290 kg

ES 22 SR

Concrete solutions. Always



 **EUROCOMACH®**

TECHNICALS SPECIFICATIONS

Operating weight with canopy (with rubber tracks)	kg	2.160
Operating weight with cabin (rubber tracks)	kg	2.290
Travelling speed	km/h	1 ^a : 0 ÷ 2,6 / 2 ^a : 0 ÷ 4,0
Slew speed	rpm	11

ENGINE

Type	YANMAR 3TNV76	
Power (2.200 rpm)	kW - HP	14,0 - 19,0
Displacement	cc	1.116
Number of cylinders	n°	3
Cooling	water	
Consumption	lt/h	2,8
Alternator	V (A)	12 (40)
Battery	V (Ah)	12 (65)

HYDRAULIC SYSTEM

Pump type	variable flow	
Pump displacement	cc	2 x 13+8,3
Pump capacity	lt/min	2 x 28+18
Max. circuit calibration pressure	bar	230
Auxiliary system: Max capacity	lt/min	46
Max pressure	bar	210

PERFORMANCES

Max digging depth standard arm (optional arm)	mm	2.493 (2.693)
Max dumping height with canopy standard arm (optional arm)	mm	2.967 (3.106)
Max dumping height with cab standard arm (optional arm)	mm	2.836 (2.957)
Bucket breaking force (standard arm) ISO 6015	daN	2.200
Arm breaking force (standard arm) ISO 6015	daN	1.520
Traction force	daN	2.000
Ground bearing pressure with rubber tracks and canopy (with cabin)	kg/cm ²	0,28 (0,30)
Max slope	60% - 30°	

DIMENSIONS

Maximum width	mm	1.450
Total height	mm	2.395
Rear rotation radius	mm	750
Digging arm length std (optional)	mm	1.150 (1.350)
Tracks width	mm	250
Rollers number (for each side)	n°	4

FILLINGS

Fuel tank	lt	26
Hydraulic oil tank	lt	29
Hydraulic circuit capacity	lt	40
Cooling system capacity	lt	5
Engine oil	lt	2,8

CONTROLS

Boom, dipper stick, bucket and turret swing	2 pilot joysticks
Track movements (included counter rotation)	2 pilot levers
Dozer blade	1 pilot lever
Auxiliary circuit (simple or double effect)	electroproportional switch on right joystick
Boom swing	electroproportional switch on left joystick

ES 22 SR

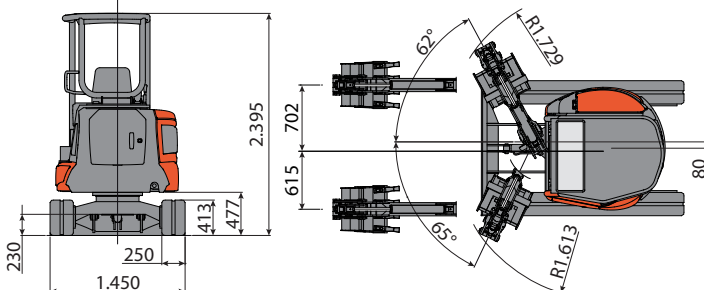
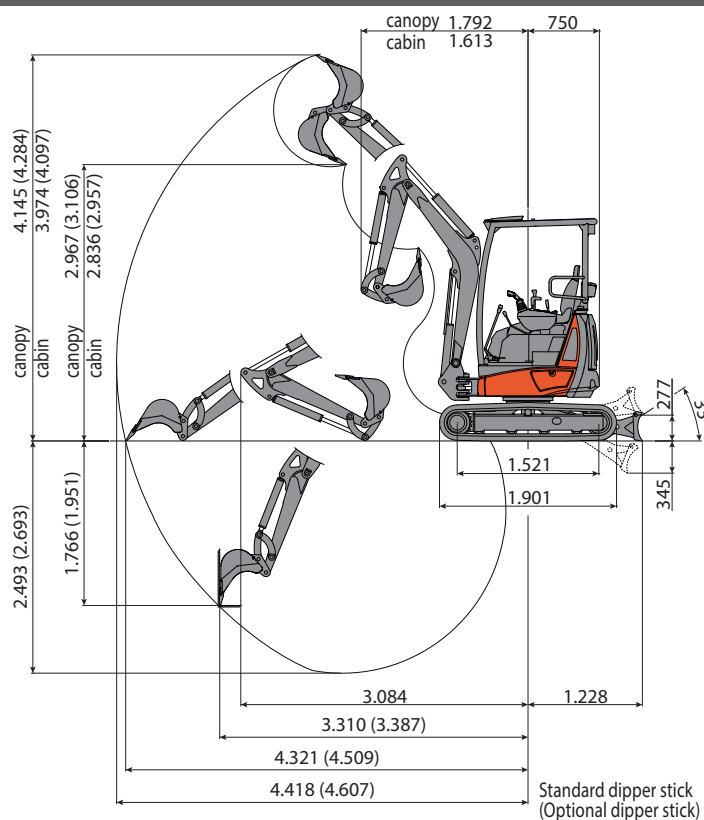

LIFTING CAPACITY

Opening arm from the rotation's center (m)

Lifting capacity (kg) at 1.0 m height

	2	2,5	3	3,5	MAX
Frontal and lowered dozer blade	948	661	531	457	431
Frontal and lifted dozer blade	788	544	413	323	293
Lateral	593	424	319	251	225

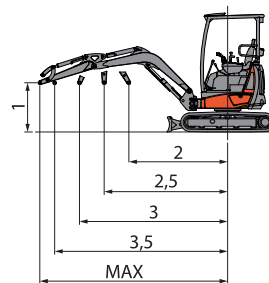

The lifting capacity is based on the ISO 10567 and it does not exceed more than the 75% of static tipping load or more than the 87% of the hydraulic lifting capacity of the machine.



EUROCOMACH®

MADE IN ITALY

Sampierana S.p.a.

47021 S.Piero in Bagno (FC)

via Leonardo da Vinci, 40

Tel +39 0543.904211

Fax +39 0543.918520

www.eurocomach.com