



ROBEX 450LC-7

Standard Equipment

ISO standard cab

- All-weather steel cab with all-around visibility
- Safety glass windows
- Raise-up type windshield wiper
- Sliding fold-in front window
- Sliding side window
- Lockable door
- Hot & cool box
- Accessory box & Ash-tray
- AM/FM radio and cassette
- Radio remote switch

Computer Aided Power Optimization

(New CAPO) system

- 2-power mode, 3-work mode, 2-user mode
- Auto deceleration & one touch deceleration system
- Auto warm up system
- Auto overheat prevention system

Self diagnostic system

Centralized monitoring

- LCD display
 - Engine speed
 - Clock & Error code
- Gauges
 - Fuel level gauge
 - Engine coolant temperature gauge
 - Hyd. oil temperature gauge
- Warning
 - Fuel level
 - Check Engine & CPU
 - Engine oil pressure
 - Engine coolant temperature
 - Hyd. oil temperature
 - Low battery
 - Air cleaner clogging
- Indicator
 - Power boost.
 - Preheat & Engine warming-up
 - One touch decel
- Starting Aid (air grille heater), cold weather

Door and cab locks, one key

Two outside rearview mirrors

Fully adjustable suspension seat with seat belt

Slidable joystick, pilot-operated

Console box tilting system (LH.)

Three front working light

Electric horn

Batteries (2 x 12V x 200AH)

Battery master switch

Removable reservoir tank

Automatic swing brake

Water separator, fuel line

Boom holding system

Arm holding system

Counterweight (9200kg, 20280lb)

Boom (7.06m, 23' 2")

Arm (3.38m, 11' 1")

Track shoes (600mm, 23.6")

Track rail guard

Travel alarm

Optional Equipment

Sun visor for cabin inside

Fuel filler pump (35 ℓ /min, 9.2 USgpm)

Beacon lamp

Safety lock valve for boom cylinder with

overload warning device

Safety lock valve for arm cylinder

Single acting piping kit (breaker, etc)

Double acting piping kit (cramshell, etc)

Accumulator, work equipment lowering

12 volt power supply (24V DC-12V DC converter)

Electric transducer

Air-conditioner(5,000kcal/hr, 20000BTU/hr)

Heater (7500kcal/hr, 30000BTU/hr)

Heater & Defroster

Various optional Arms

- Super short arm (2.40m, 7' 10")
- Short arm (2.90m, 9' 6")
- Long arm (4.00m, 13' 1")
- Super long arm (4.50m, 14' 9")

Various optional Buckets (SAE heaped)

- Standard bucket (2.15m³, 2.81yd³)
- Narrow bucket (1.38m³, 1.80yd³)
- Light duty bucket (1.84m³, 2.41 yd³)
- Light duty bucket (2.56m³, 3.35yd³)
- Light duty bucket (2.79m³, 3.65yd³)
- Light duty bucket (3.03m³, 3.96yd³)
- Heavy duty bucket (2.20m³, 2.88yd³)
- Rock bucket (2.20m³, 2.88yd³)

Cabin anti-vandalism kit

Cabin lights

FOG (Falling object guard, ISO/DIS 10262)

Track shoes

- Triple grousers shoe (700mm, 28")
- Triple grousers shoe (750mm, 30")
- Triple grousers shoe (800mm, 32")
- Triple grousers shoe (900mm, 36")

Lower frame under cover

Pre heating system

Tool kit

Operator suit

Special cowl

- Air vent type side door

Robex NEW 7 SERIES

450-7

450LC-7

Tier II Engine



CRAWLER EXCAVATOR

CUMMINS QSM11-C Engine :

263 kW/353 HP

Operating Weight :

43,700 ~ 46,500 kg (96,300 ~ 102,500 lb)

Bucket Capacity, SAE :

1.38 ~ 3.03 m³ (1.80 ~ 3.96 yd³)

■ Photo may include optional equipment.

Standard and optional equipment may vary. Contact your Hyundai dealer for more information. The machine shown may vary according to International standards.

All US measurement rounded off to nearest pounds or inches.

HYUNDAI
HEAVY INDUSTRIES CO., LTD.
CONSTRUCTION EQUIPMENT DIVISION

HEAD OFFICE 1 CHEONHA - DONG, DONG-KU, ULSAN, KOREA
(Sales Office) TEL : (82)(52)230 - 2114 FAX (82)(52)230 - 7979
U.S. Operation 955 ESTES AVENUE ELK GROVE VILLAGE IL... 60007
TEL : (1)847 - 437 - 3333 FAX : (1)847 - 437 - 3574
European Operation VOSSENDAAL 11, 2440 GEEL, BELGIUM
TEL : (32)14 - 562200 FAX : (32)14 - 593405 - 06

PLEASE CONTACT

www.hyundai-ce.com

2003. 12 Rev 2.

HYUNDAI
HEAVY INDUSTRIES CO., LTD.

Built for Maximum Power, Performance, Reliability.

A new chapter in construction equipment
has now begun.
Making the dream a reality.



■ Photo may include optional equipment.

Operator's Comfort is Foremost. Wide Cab Exceeds Industry Standards.



Visibility

- Even more visibility than before, for safer, more efficient operating.



Excellent Ventilation

- Ventilation has been improved by the addition of the larger fresh air intake system, and by providing additional air flow throughout the cab.
- Sliding front and side windows provide improved ventilation.
- A large sunroof offers upward visibility and additional ventilation.



Comfortable Operator Environment

- The control levers and seat can be adjusted to provide maximum operator comfort.
- The seat is fully adjustable for optimum operating position, reducing operator fatigue.
- Console boxes slide forward and backward for improved accessibility.
- The proportional pressure controls reduce unnecessary exertion while ensuring precise operation.
- Large windows allow excellent visibility in all directions.



Low noise design

- The Robex 7series was designed with low operation noise in mind.
- Hyundai engineering helps to keep interior and exterior noise levels to a minimum.
- The cab's noise levels have been additionally reduced by improving the door seals for the cab and engine compartments.
- An insulated diesel engine compartment with sound-damping material also reduces noise.



1 2 3
 1 Wide, Comfortable Operating Space 2 Steel Cover Sunroof 3 Dial Type Engine Speed Switch and Key Switch





Wide Cab with Excellent Visibility

The cab is roomy and ergonomically designed with low noise level and good visibility. A full view front window and large rear and side windows provide excellent visibility in all directions.



Highly Sensitive Joystick and Easy Entrance

New joystick grips for precise control have been equipped with double switches. (Left: Power boost / One touch deceleration, Right: Horn/Optional)



Easy-to-Reach Control Panels

Switches and other essential controls are located near the operator. This helps keep operator movement to a minimum, enhancing control with less operator fatigue.

Wide, Comfortable Operating Space

All the controls are designed and positioned according to the latest ergonomic research. Reinforced pillars have also been added for greater cab rigidity.



Remote Radio Control and Deluxe Cassette



Raise-up Wiper and Cabin Lights

Raise-up wiper has enhanced for the better front view. Cabin Lights enhances safety by brightly lighting the surroundings during night work (optional).



The best working conditions in a pleasant environment.

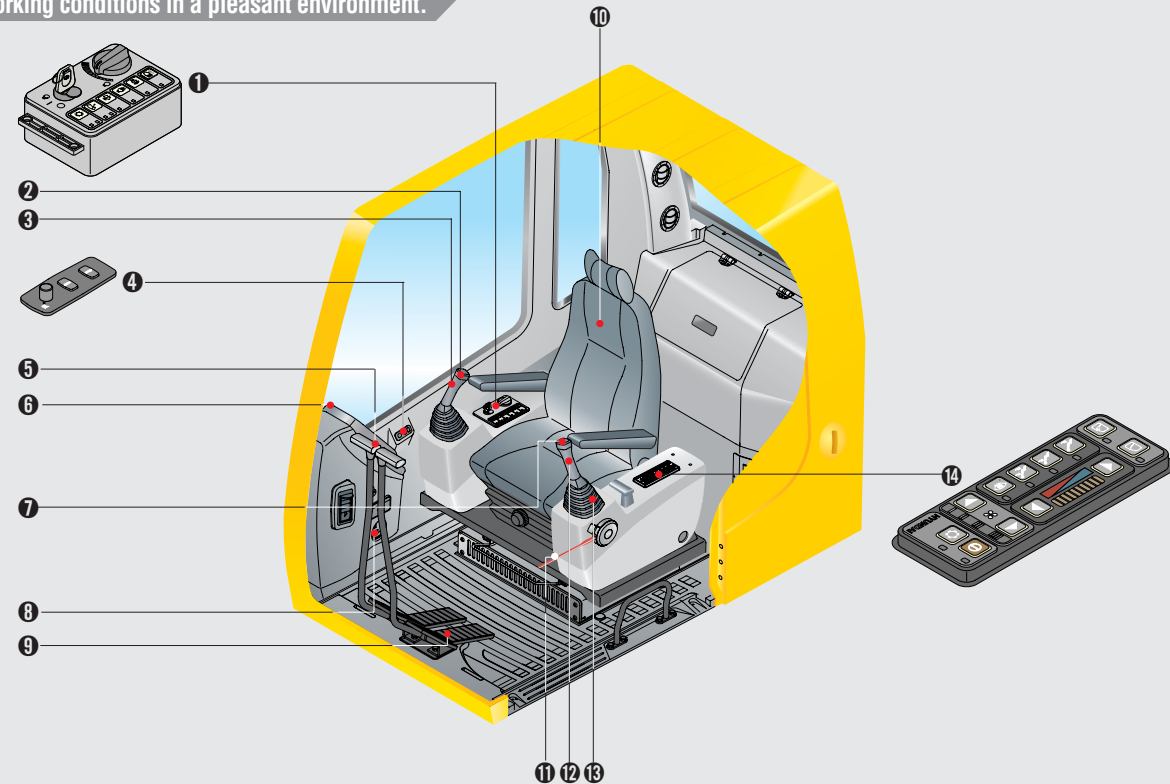

- 1 Centralized control pannel
- 2 Horn button
- 3 Option button
- 4 Remote Radio control
- 5 Travel lever
- 6 Cluster
- 7 One touch decel button
- 8 Hour meter
- 9 Travel pedal
- 10 Fully adjustable suspension seat
- 11 Safety lever
- 12 Power boost button
- 13 Joystick control lever
- 14 Air Conditioner and Heater controller

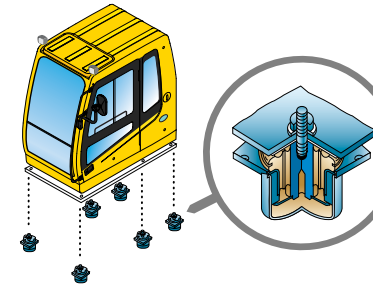

Minimization of Shock and Vibration through Cab Mounting System

The application of Viscous Mounting to the cabin support provides the operator with a much improved ride. The operator work efficiency will increase as the shock and noise level in the cabin decreases.

Improved Intelligent Display

Instrument Panel is installed in front of RH console box. It is easy to check all critical systems with easy-to-read indicators.



Smooth Travel Pedal and Foot Rests



Rear Emergency Exit Window

Rear Exit Window is designed with easy exit for operator's safety.



Storage box and Cup Holder

An Additional storage box and cup holder are located behind operator's seat, and it keeps food and beverages cool or hot.



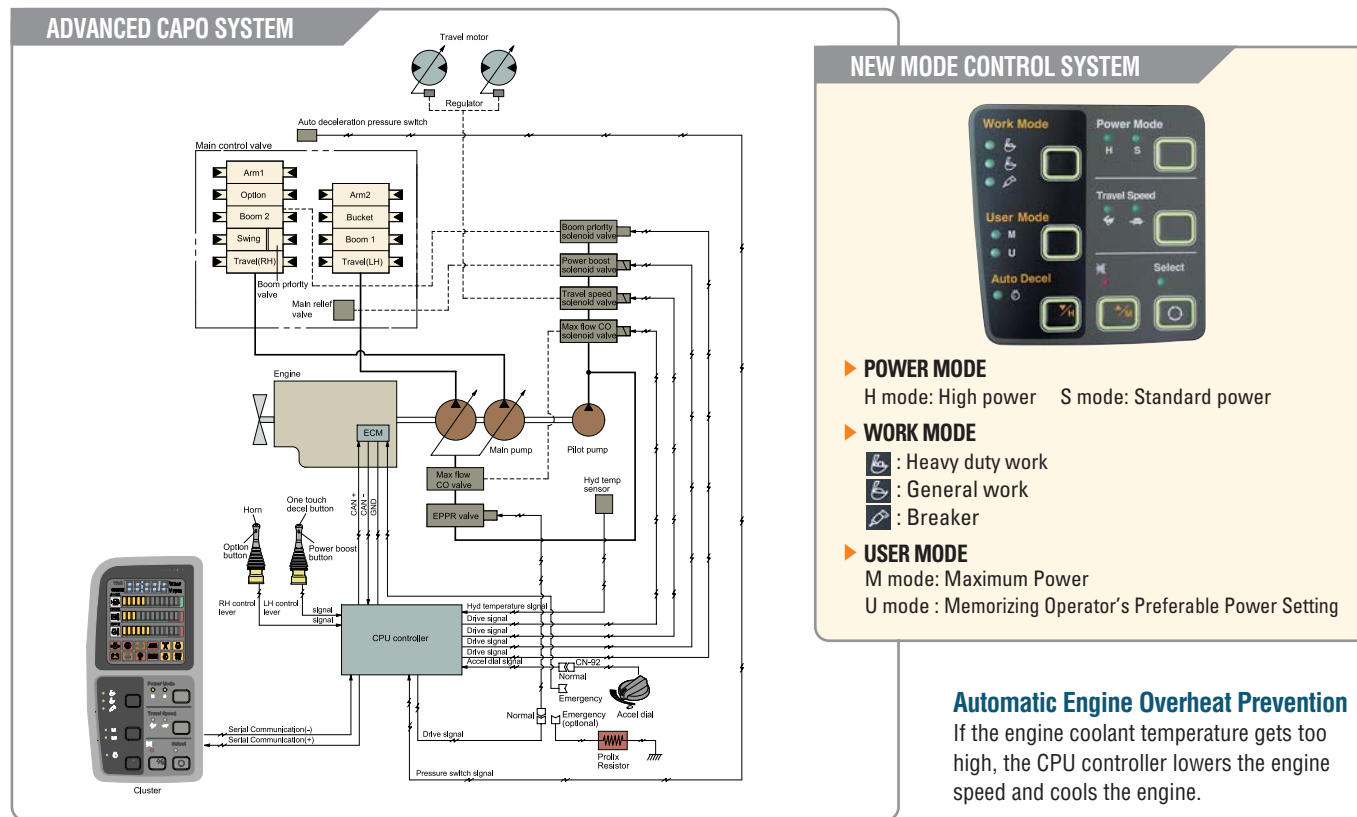

Advanced CAPO System

The Advanced CAPO (Computer Aided Power Optimization) system maintains engine and mutual pump power at optimum levels. Mode selections are designed for various work loads and maintaining high performance while reducing fuel consumption. Features such as auto deceleration and power boost are included in the system. The system monitors engine speed, coolant temperature, and hydraulic oil temperature. Contained within the system are self diagnostic capabilities which are displayed by error codes on the cluster.

Self Diagnosis System

The CPU controller diagnoses problems in the CAPO system caused by electric and hydraulic malfunctions and displays them on the LCD monitor of the cluster through error codes. This controller has the capacity to identify 48 distinct types of errors. As the information from this device, such as engine rpm, main pump delivery pressure, battery voltage, hyd. temperature, and the state of all types of electric switches, provides the operator with a much more exact state of machine operating condition. This makes the machine easier to troubleshoot when anything does go wrong.

Arm Flow Regeneration System

Arm flow regeneration valve provides smooth arm-in operation without cavitation.

Boom & Arm Holding System

The Holding valves in the main control valve prevents the boom & arm from dropping over an extended period in neutral position.

Auto Deceleration System

When remote-control valves are in neutral position more than 4 seconds, CPU controller instructs to reduce engine speed. This decreases fuel consumption and reduces cab noise levels.

One Touch Decel System

When the one touch decel switch is pressed, CPU controller controls the accel actuator to reduce engine speed to low idle rpm. And then the one touch decel switch is pressed again, the engine speed recovers.

Max. Flow Cut-off System

For precise control and finishing work, the Max. Flow Cut-off System reduces pump flow, thus allowing smooth operation.

NEW MODE CONTROL SYSTEM

- ▶ **POWER MODE**
H mode: High power S mode: Standard power
- ▶ **WORK MODE**
 - ▶ Heavy duty work
 - ▶ General work
 - ▶ Breaker
- ▶ **USER MODE**
 - M mode: Maximum Power
 - U mode: Memorizing Operator's Preferable Power Setting

Automatic Engine Overheat Prevention

If the engine coolant temperature gets too high, the CPU controller lowers the engine speed and cools the engine.

Anti Restart System

The new system protects the starter from restarting during engine operation, even if the operator accidentally turns the start key again.

Power boost control System

When the power boost system is activated, digging power increases about 10%. It is especially useful when extra power is temporarily needed, for instance, when digging hard earth and rock, or if the bucket teeth are stopped by a stubborn tree root.

Automatic Warming-up System

After the engine is started, if the engine coolant temperature is low, the CPU controller increases the engine speed and automatically increases the pump flow rate to warm up the engine more effectively.

Pump Flow Control System

In neutral position: Pump flow is reduced to a minimum to eliminate power loss. In operation: Maximum pump flow is delivered to the actuator to increase the speed. With movement of the control lever, pump flow is automatically adjusted and the actuator speed can be proportionally controlled.

Hydraulic Damper in Travel Pedal

Improved travel controllability & feeling by shock reducing when starting and stopping.

CUMMINS QSM11-C Engine

The six cylinders, turbo-charged, 4 cycle, Charger air cooled engine is built for power, reliability, economy and low emissions. This engine meets Tier II emissions regulations.

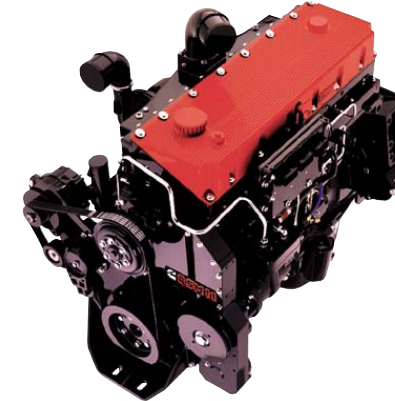

Setting the standard in clean, efficient power.

The QSM uses advanced electronic controls to meet the toughest emissions standards without compromising anything. Exceptional fuel efficiency, durability, dependability and the highest power-to-weight ratio in its class are still trademark QSM qualities. Plus, the QSM now runs quieter and cleaner.

The QSM engine comes with powerful Electronic Control Module (ECM). Using input from sensors located throughout the engine, it governs the timing and metering of fuel to the engine. Fuel is injected into the power cylinder using Cummins dual-pulse technology. This injection method helps reduce noise levels as it increases responsiveness and improves fuel efficiency.

Reinforced Bucket and Bucket Linkage

Sealed and adjustable bucket linkage provides less wear of pins and bushes as well as silent operation. The design includes bucket link durability and anti wear characteristics. Additional reinforcement plates on cutting edge section. Reinforced bucket is made with thicker steel and additional lateral plate.



Strong and Stable Lower Frame

Reinforced box-section frame is all welded, low-stress, high-strength steel. It guarantees safety and resistance against external impact when driving on rough ground and working on wet sites through high tensile strength steel panels, with highly durable upper and lower rollers and track guards. Long undercarriage incorporates heavy duty excavator style components. X-leg type center frame is integrally welded for maximum strength and durability.



Track Rail Guide & Adjusters

Durable track rail guides keep track links in place. Track adjustment is made easy with standard grease cylinder track adjusters and shock absorbing springs.

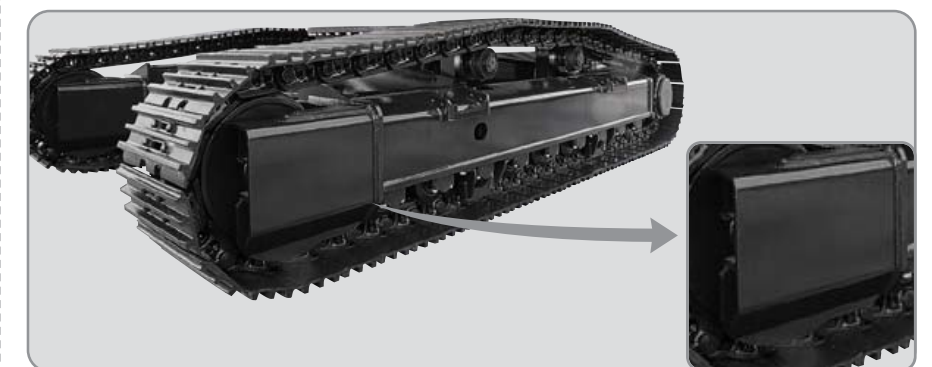

Powerful and Preciser Swing Control

Improved shock absorbing characteristics make stopping a precise and smooth action



Full open doors and master key system provide easy access for servicing.

Handrails and foot steps are applied for safety

Durability of structure proven through FEM (Finite Element Method) analysis and long term durability test.

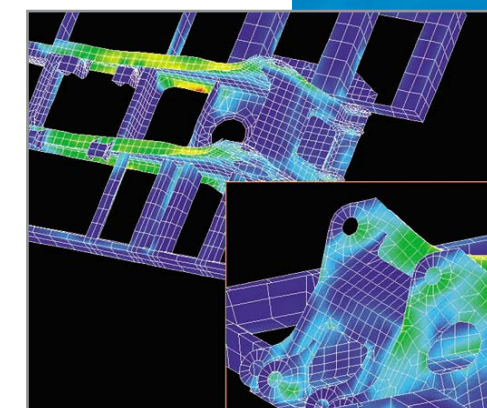

Side Cover with Left & Right Swing Open Type

Easy access to vital components gives unrestricted view of component allows easy maintenance and repair.



Easy to maintain engine components

The cooling and preheating system are provided for optimum and immediate operation, guaranteeing longer life for the engine and hydraulic components. Servicing of the engine and hydraulics is considerably simplified due to total accessibility.



Centralized Electric Control Box and Easy Change Air Cleaner Assembly

Electric control box and Air cleaner are centralized in one or the same compartment for easy service.



Highly efficient Hydraulic Pump

Pump output and Hydraulic tank capacity have been increased. A pilot pump has been installed resulting in improved control sensitivity.



Large tool box for extra storage



■ Photo may include optional equipment.

Engine

Model		Cummins QSM11-C	
Type		Watercooled, 4 cycle Diesel, 6-Cylinders in line, direct injection, Turbocharged, Charger air cooled, Low emission	
Rated flywheel horse power			
SAE	J1995 (gross)	HP(kW)/rpm	353 (263) / 1900
	J1349 (net)		320 (239) / 1900
DIN	627 1/1 (gross)	PS(kW)/rpm	358 (263) / 1900
	627 1/1 (net)		325 (239) / 1900
Max. torque	kgf·m(lbf·ft)/rpm	182.5 (1320) / 1300	
Bore x stroke	mm (in)	125 (4.92) x 147(5.79)	
Piston displacement	cc (in ³)	10,800 (659)	
Batteries		2 x 12V x 200AH	
Starting motor		24V, 7.2kw	
Alternator		24V, 50Amp	

Hydraulic system

Main pump	
Type	Two variable displacement piston pumps
Max. flow	2x380 l/min (100.4 US gpm / 83.6 UK gpm)
Sub-pump for pilot circuit	Gear pump
Cross-sensing and fuel saving pump system	
Hydraulic motors	
Travel	Two speed axial piston motor with brake valve and parking brake
Swing	Axial piston motor with automatic brake
Relief valve setting	
Implement circuits	330 kgf/cm ² (4690 psi)
Travel	345 kgf/cm ² (4910 psi)
Power boost (boom, arm, bucket)	360 kgf/cm ² (5120 psi)
Swing circuit	285 kgf/cm ² (3770 psi)
Pilot circuit	35 kgf/cm ² (500 psi)
Service valve	Installed
Hydraulic cylinders	
No. of cylinder-bore x rod x stroke	Boom: 2-170×120×1570 mm (6.7"×4.7"×61.8")
	Arm: 1-185×125×1820 mm (7.3"×4.9"×71.7")
	Bucket: 1-160×110×1370 mm (6.3"×4.3"×53.9")

Drives & Brakes

Drive method	Fully hydrostatic type
Drive motor	Axial piston motor, in-shoe design
Reduction system	Planetary reduction gear
Max. drawbar pull	37,200 kgf (82,000 lbf)
Max. travel speed(high) / (low)	5.3 km/hr (3.3 mph) / 3.2 km/hr (2.0 mph)
Gradeability	35° (70 %)
Parking brake	Multi wet disc

Control

Pilot pressure operated joysticks and pedals with detachable lever provide almost effortless and fatigueless operation.

Pilot control	Two joysticks with one safety lever (LH): Swing and arm, (RH): Boom and bucket(ISO)
Traveling and steering	Two levers with pedals
Engine throttle	Electric, Dial type
External Lights	Two lights mounted on the boom one under the battery box

Swing system

Swing motor	Axial piston motor
Swing reduction	Planetary gear reduction
Swing bearing lubrication	Grease-bathed
Swing brake	Multi wet disc
Swing speed	10.3 rpm

Coolant & Lubricant capacity

(refilling)	liter	US gal	UK gal
Fuel tank	610	161.2	134.2
Engine coolant	50.0	13.2	11.0
Engine oil	37.9	10.0	8.3
Swing device(each)	5.0	1.3	1.1
Final drive(each)	5.0	1.3	1.1
Hydraulic system(including tank)	380	100.4	83.6
Hydraulic tank	250	66.1	55.0

Undercarriage

X-leg type center frame is integrally welded with reinforced box-section track frames. The undercarriage includes lubricated rollers, idlers, track adjusters with shock absorbing spring and sprocket, assembled track chain with triple grouser shoes.

Description	R450LC-7	R450-7
Center frame	X - leg type	
Track frame	Pentagonal box type	
No. of shoes on each side	53	49
No. of carrier roller on each side	2	2
No. of track roller on each side	9	7
No. of track guard on each side	2	2

Operating weight (approximate)

Operating weight, including 7,060mm (23' 2") boom, 3,380mm (11' 1") arm, SAE heaped 2.15m³ (2.81 yd³) backhoe bucket, lubricant, coolant, full fuel tank, hydraulic tank and the standard equipment.

Major component weight

Upperstructure	8,710kg (19,200lb)
Counterweight	9,200kg (20,280lb)
Boom (with Arm cylinder)	3,910kg (8,620lb)

Operating weight

Model	Shoes (Triple grouser) mm(in)	Operating weight kg(lb)	Ground pressure kgf/cm ² (psi)
R450LC-7	※600 (24)	44,900 (99,000)	0.78 (11.09)
	700 (28)	45,400 (100,100)	0.67 (9.53)
	750 (30)	45,700 (100,800)	0.63 (8.96)
	800 (32)	46,000 (101,400)	0.60 (8.53)
R450-7	900 (36)	46,500 (102,500)	0.54 (7.68)
	600 (24)	43,700 (96,300)	0.76 (10.81)

※ Standard equipment

Buckets

SAE heaped m ³ (yd ³)	1.37 (1.80)	1.84 (2.41)	2.56 (3.35)	2.79 (3.65)	3.03 (3.96)	2.20 (2.88)	1.80 (2.35)	2.20 (2.88)
		※2.15 (2.81)						

Capacity m ³ (yd ³)	Width mm (in)	Weight kg (lb)	Recommendation mm(ft.in)						
			7060 (23' 2")	6550 (21' 6")	2400 (7' 10")	2900 (9' 6")	3380 (11' 1")	4000 (13' 1")	4500 (14' 9")
1.38 (1.80)	1,100 (43.3)	1360 (3000)	●	●	●	●	●	●	●
1.84 (2.41)	1,420 (55.9)	1540 (3400)	●	●	■	■	▲	▲	●
※2.15 (2.81)	1,610 (63.4)	1620 (3570)	●	●	■	▲	▲	▲	●
2.56 (3.35)	1,870 (73.6)	1830 (4030)	■	▲	▲	▲	-	-	■
2.79 (3.65)	2,020 (79.5)	1950 (4300)	▲	▲	▲	-	-	-	■
3.03 (3.96)	2,170 (85.4)	2020 (4450)	-	-	-	-	-	-	▲
2.20 (2.88)	1,810 (71.3)	2040 (4500)	●	●	■	■	▲	▲	●
1.80 (2.35)	1,480 (58.3)	1930 (4250)	●	●	●	●	●	■	●
2.20 (2.88)	1,810 (71.3)	2200 (4850)	■	■	▲	▲	▲	▲	●

※: Standard backhoe bucket / ■: Heavy-duty / ●: Rock bucket-Heavy duty

●: Applicable for materials with density of 2,000 kg / m³ (3,370 lb/ yd³) or less
 ■: Applicable for materials with density of 1,600 kg / m³ (2,700 lb/ yd³) or less
 ▲: Applicable for materials with density of 1,100 kg / m³ (1,850 lb/ yd³) or less

Backhoe attachment

Boom and arms are of all-welded, low-stress, full-box section design. 7060mm(23' 2"), 6550mm(21' 6")boom and 2400mm(7' 10"), 2900mm(9' 6"), 3380mm(11' 1"), 4000mm(13' 1"), 4500mm(14' 9")arms are available. Hyundai Buckets are all-welded, high-strength steel implements.

2400mm (7' 10")	2900mm (9' 6")	※3380mm (11' 1")	4000mm (13' 1")	4500mm (14' 9")
-----------------	----------------	------------------	-----------------	-----------------

Digging force

Arm	Length	mm(ft.in)	2400 (7' 10")	2900 (9' 6")	※3380 (11' 1")	4000 (13' 1")	4500 (14' 9")	Remark
			Weight	kg(lb)	2070 (4560)	2230 (4920)	2100 (4630)	
Bucket digging force	SAE	kN	223.6 [243.9]	223.6 [243.9]	223.6 [243.9]	223.6 [243.9]	223.6 [243.9]	[]: Power Boost
		kgf	22800 [24870]	22800 [24870]	22800 [24870]	22800 [24870]	22800 [24870]	
	lbf	50270 [54840]	50270 [54840]	50270 [54840]	50270 [54840]	50270 [54840]		
	ISO	kN	256.0 [279.2]	256.0 [279.2]	256.0 [279.2]	256.0 [279.2]	256.0 [279.2]	
Arm crowd force	SAE	kgf	26100 [28470]	26100 [28470]	26100 [28470]	26100 [28470]	26100 [28470]	
		lbf	57540 [62770]	57540 [62770]	57540 [62770]	57540 [62770]	57540 [62770]	
	ISO	kN	265.8 [289.9]	215.7 [235.4]	180.4 [196.8]	163.8 [178.7]	153.0 [166.9]	
	kgf	27100 [29560]	22000 [24000]	18400 [20070]	16700 [18220]	15600 [17020]		
	lbf	59750 [65180]	48500 [52910]	40570 [44260]	36820 [40170]	34390 [37520]		
	ISO	kN	278.5 [303.8]	225.6 [246.1]	187.3 [204.3]	169.7 [185.1]	157.9 [172.2]	
	kgf	28400 [30980]	23000 [25090]	19100 [20840]	17300 [18870]	16100 [17560]		
	lbf	62610 [68300]	50710 [55320]	42110 [45940]	38140 [41610]	35490 [38720]		

Note : Arm weight including bucket cylinder and linkage. ※Standard arm

Dimensions & Working ranges

Dimensions

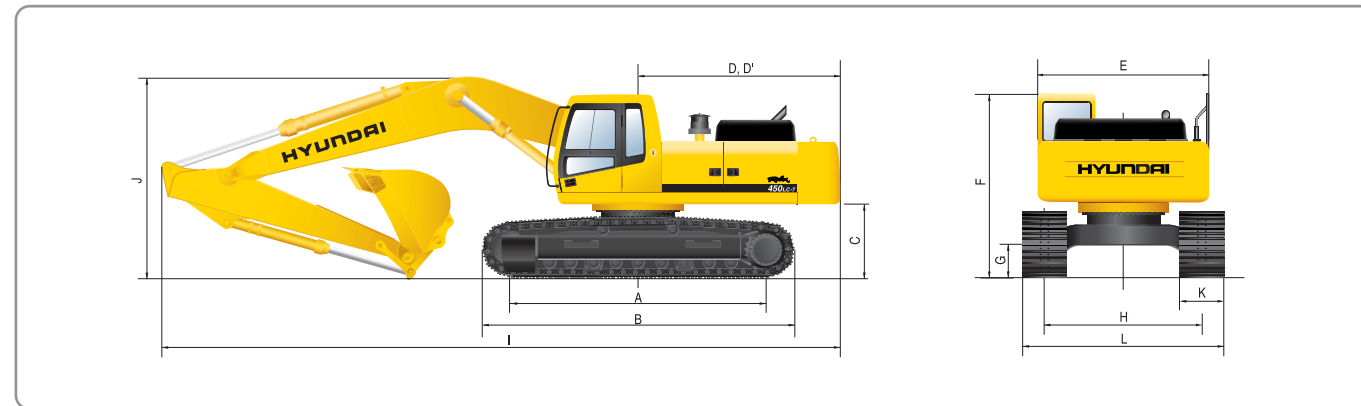

mm (ft · in)

Description	R450LC-7	R450-7
A Tumbler distance	4470 (14' 8")	4040 (13' 3")
B Overall length of crawler	5462(17' 11")	5032 (16' 6")
C Ground clearance of CWT	1340 (4' 5")	
D Tail swing radius	3720 (12' 2")	
D' Rear-end length	3665 (12' 0")	
E Overall width of upperstructure	2980 (9' 9")	
F Overall height of cab	3250 (10' 8")	
G Min. ground clearance	555 (1' 10")	
H Track gauge	2740 (9' 0")	

Description		mm (ft · in)				
I Boom length		※ 7060 (23' 2") 6550 (21' 6")				
J Arm length		2400 (7' 10")	2900 (9' 6")	※ 3380 (11' 1")	4000 (13' 1")	4500 (14' 9")
K Overall length		12230 (40' 1")	12160 (39' 11")	12000 (39' 4")	11970 (39' 3")	11910 (39' 1")
L Overall height of boom		3820 (12' 6")	3750 (12' 4")	3600 (11' 10")	4040 (13' 3")	4090 (14' 9")
M Track shoe width		※ 600 (24")	700 (28")	750 (30")	800 (32")	900 (36")
N Overall width		3340 (10' 11")	3440 (11' 3")	3490 (11' 5")	3540 (11' 7")	3640 (11' 11")

※ Standard Equipment

Working ranges

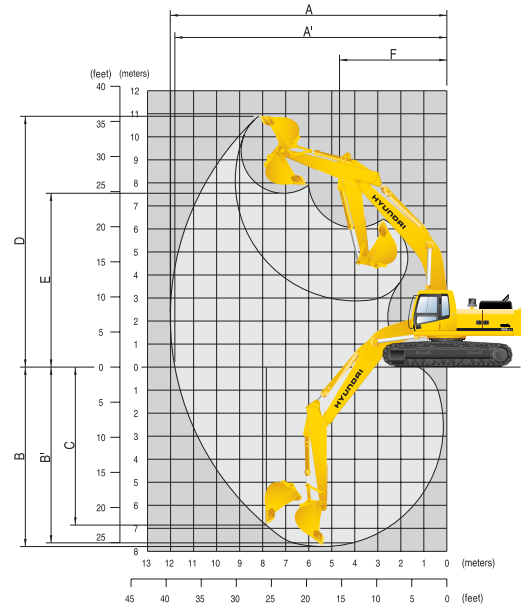

Description		mm (ft · in)				
Boom length		※ 7060(23' 2") 6550(21' 6")				
Arm length		2400 (7' 10")	2900 (9' 6")	※ 3380 (11' 1")	4000 (13' 1")	4500 (14' 9")
A Max. digging reach		11160 (36' 7")	11550 (37' 11")	12100 (39' 8")	12660 (41' 6")	13150 (43' 2")
A' Max. digging reach on ground		10940 (35' 11")	11340 (37' 2")	11900 (39' 1")	12470 (40' 11")	12960 (42' 6")
B Max. digging depth		6810 (22' 4")	7310 (23' 12")	7790 (25' 7")	8410 (27' 7")	8910 (29' 3")
B' Max. digging depth (8' level)		6620 (21' 9")	7140 (23' 5")	7640 (25' 1")	8280 (27' 2")	8790 (28' 10")
C Max. vertical wall digging depth		5990 (19' 8")	5850 (19' 2")	6560 (21' 6")	7290 (23' 11")	7690 (25' 3")
D Max. digging height		10600 (34' 9")	10550 (34' 7")	11030 (36' 2")	11250 (36' 11")	11500 (37' 9")
E Max. dumping height		7190 (23' 7")	7240 (23' 9")	7660 (25' 2")	7880 (25' 10")	8120 (26' 8")
F Min. swing radius		5090 (16' 8")	4900 (16' 1")	4780 (15' 8")	4830 (15' 10")	4870 (15' 12")

※ Standard Equipment

Lifting Capacities

Lifting capacities

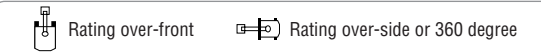

• Boom: 6.55 m (21' 6") • Arm: 2.40 m (7' 10") • Bucket: 2.15 m³ (2.81yd³) SAE heaped • Shoe : 600mm(24") triple grouser with 9,200kg(20,280 lb) CWT

Load Point height m(ft)	Load radius								At max. reach		
	3.0m (10.0ft)		4.5m (15.0ft)		6.0m (20.0ft)		7.5m (25.0ft)		Capacity	Reach	
	Hook	Bucket	Hook	Bucket	Hook	Bucket	Hook	Bucket	kg (lb)	m (ft)	
6.0m 20.0ft					12780 (28180)	12740 (28090)	11340 (25000)	8630 (19030)	9810 (21630)	6110 (13470)	9.15 (30.3)
4.5m 15.0ft			18830 (41510)	18830 (41510)	14310 (31550)	12060 (26590)	11990 (26430)	8340 (18390)	9350 (20610)	5390 (11880)	9.65 (31.7)
3.0m 10.0ft					15980 (35230)	11290 (24890)	12790 (28200)	7970 (17570)	8850 (19510)	5040 (11110)	9.86 (32.3)
1.5m 5.0ft					17360 (38270)	10670 (23520)	13390 (29520)	7630 (16820)	8810 (19420)	4980 (10980)	9.80 (32.2)
Grond Line			23370 (51520)	16020 (35320)	17360 (38270)	10320 (22750)	13260 (29230)	7400 (16310)	9240 (20370)	5210 (11490)	9.47 (31.1)
-1.5m -5.0ft	25360 (55910)	25360 (55910)	21560 (47530)	16060 (35410)	16520 (36420)	10220 (22530)	12770 (28150)	7330 (16160)	9630 (21230)	5840 (12870)	8.83 (29.0)
-3.0m -10.0ft	22500 (49600)	22500 (49600)	18450 (40680)	16320 (35980)	14370 (31680)	10350 (22820)			8790 (19380)	7250 (15980)	7.80 (25.6)
-4.5m -15.0ft			13260 (29230)	13260 (29230)							

• Boom: 7.06 m (23' 2") • Arm: 2.40 m (7' 10") • Bucket: 2.15 m³ (2.81yd³) SAE heaped • Shoe : 600mm(24") triple grouser with 9,200kg(20,280 lb) CWT

Load Point height m(ft)	Load radius								At max. reach		
	3.0m (10.0ft)		4.5m (15.0ft)		6.0m (20.0ft)		7.5m (25.0ft)		9.0m (30.0ft)		
	Hook	Bucket	Hook	Bucket	Hook	Bucket	Hook	Bucket	Hook	Bucket	
6.0m 20.0ft					12300 (27120)	12300 (27120)	10680 (23550)	8520 (18780)			
4.5m 15.0ft					13990 (30840)	11690 (25770)	11480 (25310)	8150 (17970)			
3.0m 10.0ft					15700 (34610)	10860 (23940)	12360 (27250)	7730 (17040)	10100 (22270)	5710 (12590)	
1.5m 5.0ft					16810 (37060)	10250 (22600)	13030 (28730)	7370 (16250)	9890 (21800)	5520 (12170)	
Grond Line					16990 (37460)	9940 (21910)	12980 (28620)	7140 (15740)			
-1.5m -5.0ft			20830 (45920)	15630 (34460)	16280 (35890)	9880 (21780)	12760 (28130)	7070 (15590)			
-3.0m -10.0ft	21370 (47110)	21370 (47110)	18310 (40370)	15910 (35080)	14570 (32120)	10010 (22070)	11280 (24870)	7170 (15810)			
-4.5m -15.0ft			14290 (31500)	14290 (31500)	11310 (24930)	10380 (22880)					

• Boom: 7.06 m (23' 2") • Arm: 2.90 m (9' 6") • Bucket: 2.15 m³ (2.81yd³) SAE heaped • Shoe : 600mm(24") triple grouser with 9,200kg(20,280 lb) CWT

Load Point height m(ft)	Load radius								At max. reach		
	3.0m (10.0ft)		4.5m (15.0ft)		6.0m (20.0ft)		7.5m (25.0ft)		9.0m (30.0ft)		
	Hook	Bucket	Hook	Bucket	Hook	Bucket	Hook	Bucket	Hook	Bucket	
6.0m 20.0ft							10030 (22110)	8630 (19030)			
4.5m 15.0ft			17510 (38600)	17510 (38600)	13150 (28990)	11890 (26210)	10900 (24030)	8230 (18140)	9570 (21100)	5950 (13120)	
3.0m 10.0ft			21350 (47070)	16840 (37130)	15000 (33070)	11000 (24250)	11880 (26190)	7770 (17130)	10050 (22160)	5710 (12590)	
1.5m 5.0ft			22470 (49540)	15690 (34590)	16360 (36070)	10300 (22710)	12690 (27980)	7360 (16230)	9860 (21740)	5490 (12100)	
Grond Line			23020 (50750)	15360 (33860)	16880 (37210)	9890 (21800)	12930 (28510)	7080 (15610)	9680 (21340)	5320 (11730)	
-1.5m -5.0ft	19180 (42280)	19180 (42280)	21760 (47970)	15380 (33910)	16500 (36380)	9740 (21470)	12780 (28180)	6950 (15320)			
-3.0m -10.0ft	24800 (54670)	24800 (54670)	19550 (43100)	15590 (34370)	15180 (33470)	9810 (21630)	11820 (26060)	6980 (15390)			
-4.5m -15.0ft			19830 (43720)	16030 (35340)	16030 (35340)	12570 (27710)	10080 (22220)				

NOTES
 1. Lifting capacity are based on SAE J1097, ISO 10567.
 2. Lifting capacity of the Robex Series does not exceed 75% of tipping load with the machine on firm, level ground or 87% of full hydraulic capacity.
 3. The load point is a hook (standard equipment) located on the back of the bucket.
 4. (*) indicates load limited by hydraulic capacity.

Lifting capacities

Rating over-front Rating over-side or 360 degree

• Boom: 7.06 m (23' 2") • Arm: 3.38 m (11' 1") • Bucket: 2.15 m³ (2.81yd³) SAE heaped • Shoe : 600mm(24") triple grouser with 9,200kg(20,280 lb) CWT

Load Point height m(ft)	Load radius										At max. reach		
	3.0m (10.0ft)		4.5m (15.0ft)		6.0m (20.0ft)		7.5m (25.0ft)		9.0m (30.0ft)		Capacity	Reach	
													m (ft)
6.0m 20.0ft	kg lb												
4.5m 15.0ft	kg lb												
3.0m 10.0ft	kg lb												
1.5m 5.0ft	kg lb												
Grond Line	kg lb												
-1.5m -5.0ft	kg lb												
-3.0m -10.0ft	kg lb												
-4.5m -15.0ft	kg lb												
-6.0m -20.0ft	kg lb												

• Boom: 7.06 m (23' 2") • Arm: 4.00 m (13' 1") • Bucket: 2.15 m³ (2.81yd³) SAE heaped • Shoe : 600mm(24") triple grouser with 9,200kg(20,280 lb) CWT

Load Point height m(ft)	Load radius										At max. reach			
	3.0m (10.0ft)		4.5m (15.0ft)		6.0m (20.0ft)		7.5m (25.0ft)		9.0m (30.0ft)		10.5m (35.0ft)		Capacity	Reach
6.0m 20.0ft	kg lb													
4.5m 15.0ft	kg lb													
3.0m 10.0ft	kg lb													
1.5m 5.0ft	kg lb													
Grond Line	kg lb													
-1.5m -5.0ft	kg lb													
-3.0m -10.0ft	kg lb													
-4.5m -15.0ft	kg lb													
-6.0m -20.0ft	kg lb													

• Boom: 7.06 m (23' 2") • Arm: 4.50 m (14' 9") • Bucket: 2.15 m³ (2.81yd³) SAE heaped • Shoe : 600mm(24") triple grouser with 9,200kg(20,280 lb) CWT

Load Point height m(ft)	Load radius										At max. reach			
	3.0m (10.0ft)		4.5m (15.0ft)		6.0m (20.0ft)		7.5m (25.0ft)		9.0m (30.0ft)		10.5m (35.0ft)		Capacity	Reach
6.0m 20.0ft	kg lb													
4.5m 15.0ft	kg lb													
3.0m 10.0ft	kg lb													
1.5m 5.0ft	kg lb													
Grond Line	kg lb													
-1.5m -5.0ft	kg lb													
-3.0m -10.0ft	kg lb													
-4.5m -15.0ft	kg lb													
-6.0m -20.0ft	kg lb													

NOTES 1. Lifting capacity are based on SAE J1097, ISO 10567. 2. Lifting capacity of the Robex Series does not exceed 75% of tipping load with the machine on firm, level ground or 87% of full hydraulic capacity. 3. The load point is a hook (standard equipment) located on the back of the bucket. 4. (*) indicates load limited by hydraulic capacity.

Lifting capacities

Rating over-front Rating over-side or 360 degree

• Boom: 6.55 m (21' 6") • Arm: 2.40 m (7' 10") • Bucket: 2.15 m³ (2.81yd³) SAE heaped • Shoe : 800mm(32") triple grouser with 9,200kg(20,280 lb) CWT

Load Point height m(ft)	Load radius										At max. reach		
	3.0m (10.0ft)		4.5m (15.0ft)		6.0m (20.0ft)		7.5m (25.0ft)		9.0m (30.0ft)		Capacity	Reach	
													m (ft)
6.0m 20.0ft	kg lb												
4.5m 15.0ft	kg lb												
3.0m 10.0ft	kg lb												
1.5m 5.0ft	kg lb												
Grond Line	kg lb												
-1.5m -5.0ft	kg lb												
-3.0m -10.0ft	kg lb												
-4.5m -15.0ft	kg lb												

• Boom: 7.06 m (23' 2") • Arm: 3.38 m (11' 1") • Bucket: 2.15 m³ (2.81yd³) SAE heaped • Shoe : 800mm(32") triple grouser with 9,200kg(20,280 lb) CWT

Load Point height m(ft)	Load radius										At max. reach			
	3.0m (10.0ft)		4.5m (15.0ft)		6.0m (20.0ft)		7.5m (25.0ft)		9.0m (30.0ft)		10.5m (35.0ft)		Capacity	Reach
6.0m 20.0ft	kg lb													
4.5m 15.0ft	kg lb													
3.0m 10.0ft	kg lb													
1.5m 5.0ft	kg lb													
Grond Line	kg lb													
-1.5m -5.0ft	kg lb													
-3.0m -10.0ft	kg lb													
-4.5m -15.0ft	kg lb													
-6.0m -20.0ft	kg lb													

• Boom: 7.06 m (23' 2") • Arm: 4.00 m (13' 1") • Bucket: 2.15 m³ (2.81yd³) SAE heaped • Shoe : 800mm(32") triple grouser with 9,200kg(20,280 lb) CWT

Load Point height m(ft)	Load radius										At max. reach			
	3.0m (10.0ft)		4.5m (15.0ft)		6.0m (20.0ft)		7.5m (25.0ft)		9.0m (30.0ft)		10.5m (35.0ft)		Capacity	Reach
6.0m 20.0ft	kg lb													
4.5m 15.0ft	kg lb													
3.0m 10.0ft	kg lb													
1.5m 5.0ft	kg lb													
Grond Line	kg lb													
-1.5m -5.0ft	kg lb													
-3.0m -10.0ft	kg lb													
-4.5m -15.0ft	kg lb													
-6.0m -20.0ft	kg lb													

NOTES 1. Lifting capacity are based on SAE J1097, ISO 10567. 2. Lifting capacity of the Robex Series does not exceed 75% of tipping load with the machine on firm, level ground or 87% of full hydraulic capacity. 3. The load point is a hook (standard equipment) located on the back of the bucket. 4. (*) indicates load limited by hydraulic capacity.