



Cat[®] 903D

COMPACT WHEEL LOADER

FEATURES:

The Cat[®] 903D is compact, yet powerful, delivering high performance with outstanding versatility. A 25 percent increase in lift capacity and travel speed will allow the operator to be more productive, while new optional features such as engine and ground speed control, provides customizable control when running hydro-mechanical work tools. With a more ergonomic cab, new multi-function joystick, and optional ride control, the 903D allows the operator to enjoy all day comfort.

- **Work Made Easy:** The 903D Makes Work Easy with a 25 percent increase in tipping capacity to handle classic landscaping materials along with a 25% faster ground speed. The optional Skid Steer Loader style coupler allows for changing work tools without getting out of the cab. Optional front and rear diff-lock can be activated on the fly, providing maximum traction in slick underfoot conditions.
- **Enjoy All Day Comfort:** Operators will Enjoy All Day comfort with a new multi-function joystick, increased leg room, improved pedal positioning, easier entry/exit and optional ride control. The minimal engine overhang provides excellent rear and corner visibility, making the 903D easy to operate in confined areas.

- **Configured for Success:** Configure the 903D for success with new options such as engine and ground speed control, ideally suited for hydro-mechanical work such as using a broom. With the addition of a Worktool Electrical Harness option, you can now run more tools than ever before. Two loader linkage options, standard and high lift, provide either improved capacity or improved lift height based on your application.
- **Simply Reliable:** Fully opening rear hood allows easy access to the engine compartment featuring side-by-side coolers and transparent fuel/water separator with optional engine air precleaner and radiator screen for high debris applications. New rear tie down locations under the machine allow for easier transport, while a new engine oil fill location allows for easier access during engine oil changes.

Specifications

Engine

Engine Model	Cat C2.4*	
Gross Power	31 kW	42 hp
Net Power @ 2,200 rpm		
SAE J1349 Rating	30 kW	40 hp
ISO 9249 Rating	30 kW	40 hp
Bore	87 mm	3.4 in
Stroke	102 mm	4.0 in
Displacement	2.4 L	147 in ²

*Engine meets U.S. EPA Tier 4 Final emission standards.

Weight

Operating Weight	4270 kg	9,414 lb
------------------	---------	----------

Buckets

Bucket Capacities	0.6-1.0 m ³	0.8-1.3 yd ³
-------------------	------------------------	-------------------------

Transmission

Travel Speed	20 km/h	12.4 mph
--------------	---------	----------

Hydraulic System

Main Relief	240 bar	3,481 psi
3rd Auxiliary Flow	52 L/min	14 gal/min
Hydraulic Cycle Time – Lift	4.4 seconds	
Hydraulic Cycle Time – Dump	0.7 seconds	
Hydraulic Cycle Time – Lower, Float	2.4 seconds	

Cab

ROPS	ISO 3471:2008	
FOPS	ISO 3449:2005 Level I	

Service Refill Capacities

Cooling System	11 L	3 gal
Fuel Tank	43 L	11.4 gal
Hydraulic System	24 L	6.3 gal
Engine Oil	9 L	2.4 gal



903D Compact Wheel Loader

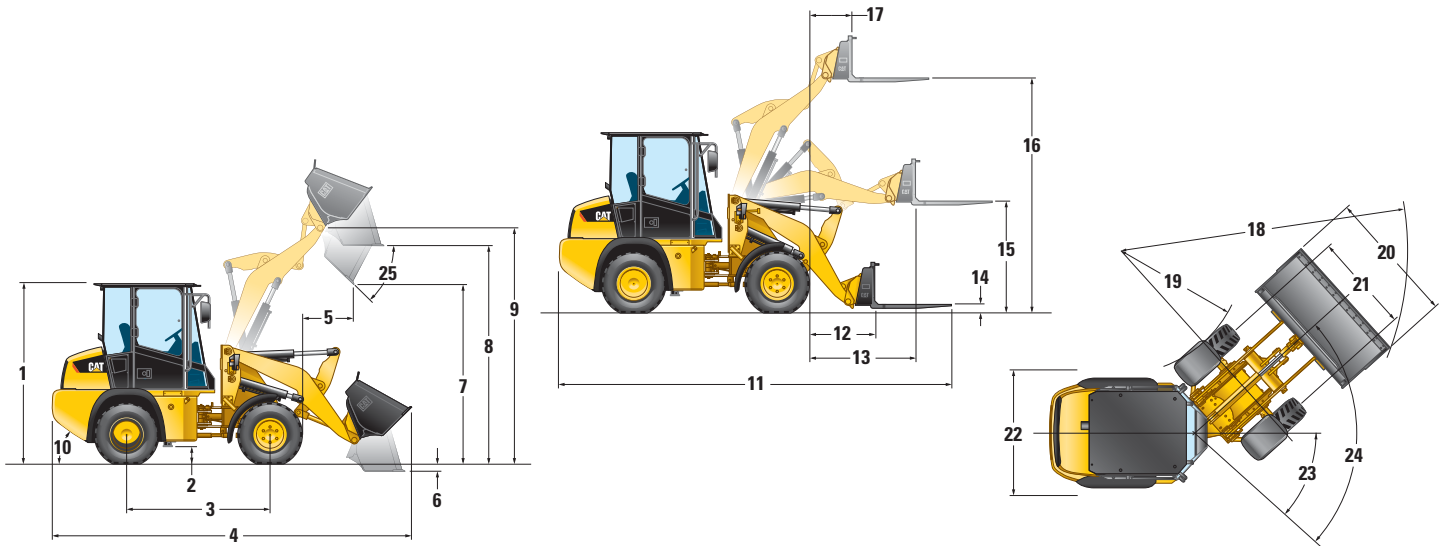

Dimensions (All dimensions are approximate.)

	Standard Lift		High Lift	
1 Cab Height	2510 mm	8 ft 3 in	2510 mm	8 ft 3 in
2 Ground Clearance	250 mm	10 in	250 mm	10 in
3 Wheelbase	1950 mm	6 ft 5 in	1950 mm	6 ft 5 in
* 4 Overall Length with Bucket	4790 mm	15 ft 9 in	4936 mm	16 ft 2 in
* 5 Reach at Maximum Dump Height	720 mm	2 ft 4 in	729 mm	2 ft 5 in
6 Dig Depth	163 mm	6 in	195 mm	8 in
* 7 Maximum Dump Height	2292 mm	7 ft 6 in	2435 mm	8 ft 0 in
8 Load Over Height	2801 mm	9 ft 2 in	2942 mm	9 ft 8 in
9 Hinge Pin at Maximum Height	3086 mm	10 ft 1 in	3227 mm	10 ft 7 in
10 Departure Angle (degrees)	30°			
11 Overall Length with Forks	5205 mm	17 ft 1 in	5363 mm	17 ft 7 in
12 Reach at Level Ground	821 mm	2 ft 8 in	979 mm	3 ft 3 in
13 Maximum Reach	1368 mm	4 ft 6 in	1486 mm	4 ft 11 in
14 Fork Depth Above Ground	40 mm	2 in	40 mm	2 in
15 Fork Height at Maximum Reach	1421 mm	4 ft 8 in	1421 mm	4 ft 8 in
16 Maximum Fork Height	3005 mm	9 ft 10 in	3146 mm	10 ft 4 in
17 Fork Reach at Maximum Height	600 mm	2 ft 0 in	609 mm	2 ft 0 in
* 18 Turning Radius Over Bucket	4007 mm	13 ft 2 in	4086 mm	13 ft 5 in
** 19 Turning Radius Inside Tire	1816 mm	5 ft 11 in	1816 mm	5 ft 11 in
* 20 Width Over Bucket	1770 mm	5 ft 10 in	1770 mm	5 ft 10 in
21 Tire Gauge	1314 mm	4 ft 4 in	1314 mm	4 ft 4 in
** 22 Machine Width	1708 mm	5 ft 7 in	1708 mm	5 ft 7 in
23 Articulation Angle	40°			
24 Steering Angle	80°			
25 Dump Angle at Maximum Height	40°			

*Vary with bucket size.

**Vary with tire size.

Dimensions listed are based on the machine configured with cab with air conditioning, remote quick coupler, general purpose bucket or 1067 mm (42 in) forks, 75 kg (165 lb) operator, 33 × 15.5-16.5, 12 PR tires, without ride control, without precleaner.

Operating Specifications

	Standard Lift		High Lift	
Tire Size	33 × 15.5-16.5, 12 PR			
Rated Bucket Capacity	0.6 m ³	0.8 yd ³	0.6 m ³	0.8 yd ³
Breakout Force	27 kN	6,160 lbf	28 kN	6,204 lbf
Operating Weight	4270 kg	9,414 lb	4292 kg	9,462 lb
Rated Operating Load @ Full Turn, Bucket***	1225 kg	2,701 lb	1135 kg	2,502 lb
Straight Tipping Load, Bucket***	2910 kg	6,415 lb	2710 kg	5,975 lb
Full Turn Static Tipping Load, Bucket (ISO 14397-1*)***	2450 kg	5,401 lb	2270 kg	5,004 lb
Full Turn Static Tipping Load, Bucket (Rigid Tire**)***	2500 kg	5,512 lb	2320 kg	5,115 lb
Rackback, Transport Position	51°			
Rated Operating Load @ Full Turn, Forks (EN 474-3:2006, Firm and Level Ground, 500 mm [20 in] Load Center) (80% FTSTL)***	1770 kg	3,902 lb	1660 kg	3,660 lb
Rated Operating Load @ Full Turn, Forks (EN 474-3:2006, Rough Terrain, 500 mm [20 in] Load Center) (60% FTSTL)***	1330 kg	2,932 lb	1250 kg	2,756 lb

*Full compliance to ISO 14397-1 (2007) Sections 1 thru 6, which requires 2% verification between calculation and testing.

**Compliance to ISO 14397-1 (2007) Sections 1 thru 5.

***Manual quick coupler, precleaner hood.

Operating specifications shown are based on machine equipped with enclosed ROPS cab with air conditioning, remote quick coupler, 75 kg (165 lb) operator and general purpose bucket (GP), without ride control, without precleaner unless otherwise noted.

Maximum Material Densities

Based on ISO 7546: 1983 and rated operating loads at full turn and standard linkage.

Bucket Type	General Purpose		Light Material	
	General Purpose	Light Material	General Purpose	Light Material
Rated Capacity	0.6 m ³	0.8 yd ³	1.0 m ³	1.3 yd ³
Dump Height	2290 mm	90 in	2160 mm	85 in
Maximum Material Density	1880 kg/m ³	3,169 lb/yd ³	1180 kg/m ³	1,989 lb/yd ³
Bucket Width	1770 mm	70 in	1880 mm	74 in

903D Compact Wheel Loader

STANDARD EQUIPMENT

POWER TRAIN

- Air cleaner, two stage with visual indicator
- Cat C2.4 engine
 - Meets U.S. EPA Tier 4 Final emission standards
- Closed circuit breather
- Cold start plugs
- Electrical fuel priming pump
- Eco drain, engine oil
- Extended life coolant protects to -37° C (-34° F)
- Frame mounted heavy duty axles with outboard planetary reduction
- Maintenance free, sealed for life, prop shaft and universal joints
- Transmission, 20 km/h (12.4 mph)

ELECTRICAL

- 12 volt direct electric starting
- Alternator, 70A
- Battery disconnect switch
- Cab mounted fuse panel
- Ignition key start/stop switch
- Maintenance free, sealed for life, 650 CCA heavy duty battery

OPERATOR ENVIRONMENT

- Cup holder
- Digital service hour meter
- Engine coolant temperature gauge
- Fuel level gauge
- Heavy duty, easy clean floor mat
- Operator warning system indicators:
 - DPF monitor
 - Parking brake applied
 - Hydraulic oil temperature
 - Engine oil pressure
 - Service brake pressure
 - Hydraulic filter bypass
- Seat
 - Static, vinyl with 51 mm (2 in) retractable seat belt
- Two external mirrors – knock back

OTHER STANDARD EQUIPMENT

- 3rd valve auxiliary hydraulics with continuous flow detent, standard flow
- Engine enclosure – lockable
- Guarded front headlight
- Hydraulic auxiliary lines with quick disconnects
- Hydraulic oil level sight gauge
- Lift arm safety brace
- Loader arm float function
- Lockable fuel filler cap
- Manual quick coupler, skid steer loader compatible
- Parking brake (secondary brake)
- Product Link™, PL240
- Quick release fuel filter/water separator
- Reversing light
- Self-canceling direction indicators
- Work tool return to dig
- Z-bar linkage

OPTIONAL EQUIPMENT

- Air conditioning/heater
- Alternator, 90 amp for air conditioning
- Antifreeze/coolant, extended life, protects to -50° C (-58° F)
- Beacon ready
- Cab
 - Open
 - Enclosed
- Differential lock, front and rear axles
- Electric quick coupler, skid steer loader compatible
- Engine air precleaner
- Engine block heater 120V (dealer installed)
- Engine Speed Control (Throttle Lock)
- Fenders
 - Rear only
 - Front and rear

- Ground Speed Control (Creeper Control)
- Linkage
 - Standard lift
 - High lift
- Radiator debris screen
- Radio Ready or AM/FM radio
- Ride Control
- Seats
 - Mechanical suspension, vinyl with 51 mm (2 in) seat belt
 - Mechanical suspension, vinyl with 75 mm (3 in) seat belt
 - Mechanical suspension, fabric with 51 mm (2 in) seat belt
 - Mechanical suspension, fabric with 75 mm (3 in) seat belt

- Tires
 - 12-16.5 10PR
 - Flotation 33-15.5 × 16.5
 - Flexport™ 33 × 6 × 11
- Working lights, front and rear
 - Halogen
 - LED
- Work Tool Electrical Harness

WORK TOOLS

- For all work tool options, consult your Cat dealer.

For more complete information on Cat products, dealer services, and industry solutions, visit us on the web at www.cat.com

AEHQ8123 (05-2018)

© 2018 Caterpillar
All rights reserved

Materials and specifications are subject to change without notice. Featured machines in photos may include additional equipment. See your Cat dealer for available options.

CAT, CATERPILLAR, SAFETY.CAT.COM, their respective logos, "Caterpillar Yellow" and the "Power Edge" trade dress, as well as corporate and product identity used herein, are trademarks of Caterpillar and may not be used without permission.

