



TM

VENIERI

SPA

1.63C

ARTICULATED
WHEEL LOADER

PRELIMINARY





Venierina



PERFECT STABILITY.

Rear oscillating axle fitted (like big loaders) with maintenance free supports.



REAR TOOL CARRIER.

Thanks to the rear hydraulic and electric connections you can easily add rear attachments.



50 HP OF PURE JAPANESE POWER.

Simplicity and reliability are the two main features that brought Venieri to choose Yanmar engines: the best in terms of power economy and emissions. 4 cylinders, direct injection, water cooled, paper dry filter. Emissions Stage IIIa/Tier III



TYRE RANGE FOR ANY KIND OF APPLICATION.

Big range of tyres selected for any kind of terrain and application: industrial, agri, construction, etc.



100% VENIERI DESIGN.

As in all Venieri new machines, our Venieri Design Center follows the "family feelings" but introduces significant stylistic innovations.



VZPK KINEMATIK.

Venieri Z-Parallel Kinematic system is engineered to reach maximum breakout force, granting **fully parallel movements**.



360 3D VIEW.

Thanks to the VF 1.63C wide cabin you get a **full 360° view**, meaning a complete and safe control of the entire working area.



AUTOMOTIVE DISK BRAKE SYSTEM.

Despite her compact size we also have installed **Disc Brake system**, generally mounted on big Loaders only: we take care about You.



3 CABINS 3 OPTIONS JUST 1 MACHINE.

Feel free to configure your VF 1.63C with **3 different type of cabin**, following your needs and your working condition.



LED LAMP.

Last generation of led lamp grant **maximum visibility** with **minimum absorb**.

1.63C

WHEEL LOADER

"VZPK" Z-PARALLEL KINEMATIK



DIESEL ENGINE

Engine: 4 cylinders, direct injection, water cooled, paper dry filter.

Emissioned according to Directive CE 97/68 stage IIIA

Type	Yanmar 4TNV88
Max power	36kW - 50 HP
Rated rpm	3.000
Net power ISO/TR 14396	35 kW - 48 HP
Net power EEC/80/1269	35 kW - 48 HP
Bore	mm 88
Stroke	mm 90
Displacement	cm ³ 2.190



ELECTRIC SYSTEM

Battery	12 Volt
Capacity EN 60095-1	80 Ah - 770 A
Alternator rating	65 A
Reverse warning	Standard
Wiring according to	IP 67 - DIN 40050



TRANSMISSION

Hydrostatic transmission with automatic power regulation and closed circuit with variable-displacement pump and engine.

Two forward/reverse speeds with single-lever control.

STD	Forward	Backward
1 st gear km/h	0÷7	0÷7
2 nd gear km/h	0÷27	0÷27

OPT	Forward	Backward
1 st gear km/h	0÷8	0÷8
2 nd gear km/h	0÷40	0÷40*

* with optional tyres



AXLES

Two heavy duty axles with planetary final drives in each wheel. All wheel drive.

Fixed rigid drive axle on front chassis section.

Oscillating drive axle on rear chassis section up to a total angle of 24°.

Transfer gearbox transferring movement directly to the rear and to the front via a transmission shaft. Self-locking limited slip differential on front axle (optional on rear axle).



BRAKES

Service: disk brake hydraulically operating on front axle, working on all wheels. Parking brake: mechanical drumbrake operating on service brake, manually actuated.



TYRES

Standard	10.0/75-15,3
Optional	12.0-16,5 • 31-15.50 -15 • 420/55 R17 • 11 LR16



STEERING

Servo assisted steering hydraulic **LOAD SENSING** system.

Total steering angle	80°
Inner tyres turning radius	mm 3.130
External tyres turning radius	mm 5.500
External bucket turning radius	mm 6.050



HYDRAULIC SYSTEM

Hydraulic gear pump with LOAD SENSING priority valve for steering circuit.

3-section modular control valve with main relief valve. Double-acting hydraulic cylinders. Hydraulic oil cooling radiator.

Full-flow oil filter on the leakage pipe. Single cloche-lever arm control with 4-position lifting system and button auxiliary system.

Max flow	lt/1'	58
Loader relief valve pressure	bar	190
Steering relief valve pressure	bar	190
Lift cylinder	mm	65x635
Bucket cylinder	mm	85x320



SERVICE CAPACITIES

Engine	lt	8
Front axle	lt	5,8
Rear axle + gear box	lt	6,5
Hydraulic circuit	lt	50
Brake system	lt	1,1
Fuel	lt	42
Water cooling	lt	9



TECHNICAL FEATURES

Standard bucket capacity	m ³	0,5
Standard bucket width	mm	1.500
Straight static tipping load	kg	2.300
Full turned 45° tipping load	kg	1.850
Lifting capacity at max. height	kg	2.170
Pin height	mm	2.960
Dump height at 42°	mm	2.290
Reach at 42°	mm	660
Breakout force	kg	3.840



DIMENSIONS AND WEIGHTS

Max length in transfer position	mm	4.300
Max width in transfer position	mm	1.500
Max height	mm	2.250
Track width - standard tyres	mm	1.100
Overall standard tyre width	mm	1.365
Wheel base	mm	1.750
Ground clearance	mm	345
Standard operating weight	kg	3.100
Max permissible weight	kg	3.600

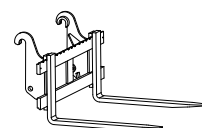
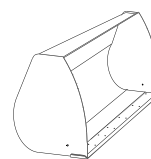
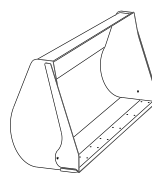
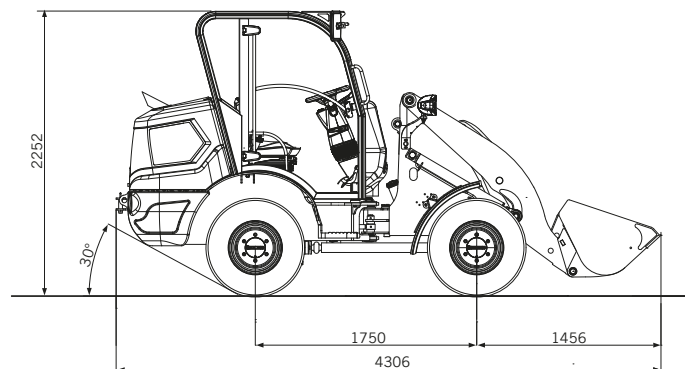
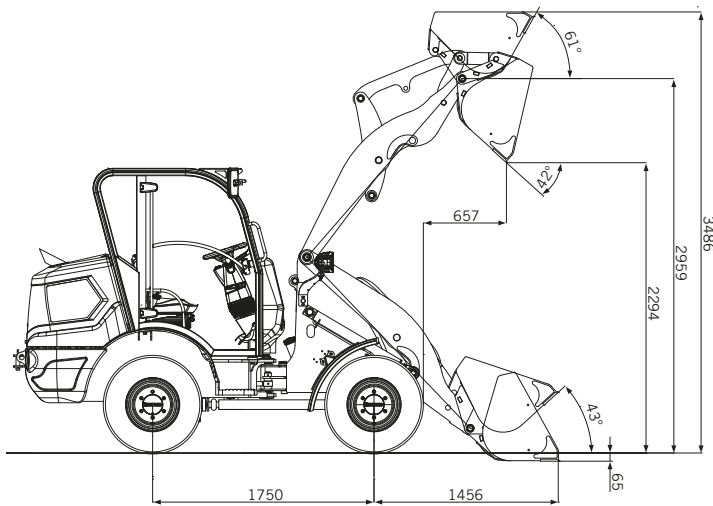

PERFORMANCE DATA

UNIVERSAL BUCKET

OVERSIZE BUCKET

FORKS

Full load bucket capacity (SAE)	m ³	0,5	0,8	/
Density	t/m ³	1,8	1	/
Bucket width	mm	1.500	1.700	/
Bucket weight	kg	180	180	/
Overall operating height, fully raised	mm	3.490	3.610	/
Forks length (standard)	mm			1.000
Forks length (optional)	mm			1.200
Hinge pin height	mm	2.960	2.960	/
Dump clearance	°	42°	42°	/
Dump height	mm	2.295	2.200	/
Dump distance	mm	660	741	/
Bucket static tipping load, straight	kg	2.300	2.150	/
Bucket static tipping load, full turn (45°)	kg	1.850	1.720	/
Forks static tipping load, full turn (45°)	kg			
Payload EN 474-3 (80%) [•]	kg			
Payload EN 474-3 (60%) [•]	kg			
Breakout force	kg	3.840	3.249	/
Total displacement length	mm	4.300	4.378	/
External bucket turning radius	mm	3.220	3.345	/
Standard operating weight (Canopy version)	kg	3.100	3.180	3.180

[•] Loading center 500mm

POWER

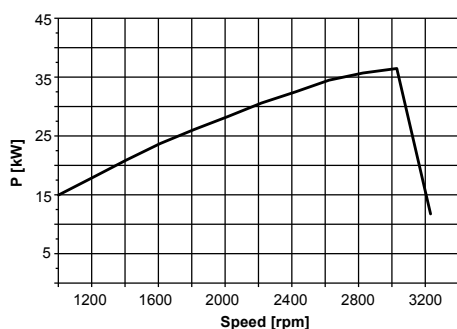

TORQUE

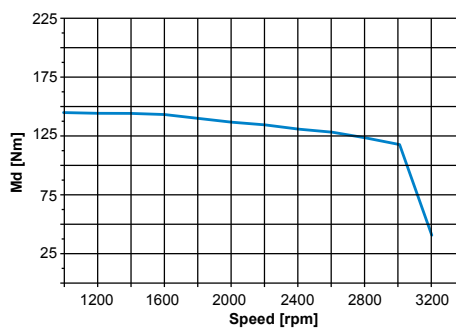

FUEL CONSUMPTION

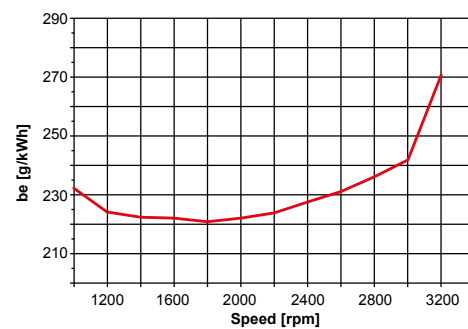

VENIERI Z PARALLEL KINEMATIC SYSTEM: 100% PARALLEL.

The arm of VF 1,63C is equipped with a VZPK kinematic system that grants high breakout force while keeping fully parallel movements. The low bucket cylinder grants an excellent front visibility also in the middle of the arm, where normally it's not easy to see.



VENIERI REAR HYDRAULIC LINE

In order to grant maximum versatility, VF 1.63C "Venierina" can be equipped with rear Hydraulic line to support rear attachments.



CABIN

CLOSE AND HEATED CABIN,
WITH AIRCONDITION IN OPTION

CANOPY

CANOPY WITH RETROFITTABLE GLASS
AND DOORS.

ROLLBAR ROOF

FOLDABLE ROLLBAR



▶ **BASIC MACHINE**



Battery main switch	•
Tool box	•
Fuel preheating (cold climates)	0
Plugs with keys for fuel and hydraulic tanks	•
Proportional self lock front differential	•
Proportional self lock rear differential	0
Differential lock 100 % engageable in front axle	0
Trailer coupling	•
Warning beacon	•
Soundproofing	•
Spare parts catalogue	•
User manual	•
Type-approval for road traffic	•
Safety clamp for bucket and lifting cylinders	•
Autolevelling ground level for bucket	•
Speed reduction kit	0
"Venieri GLOBAL" system	-
Double-speed hydraulic fan	-
Reversible fan (for radiator cleaning)	-
Hydraulic negative parking brake	-
Service brake on front axle	•
Inch pedal integrated in brake pedal	0
Greasing points grouped on the frame	0
Automatic centralized greasing system	0
Ride control	0
Engine preheating system	0
Environmentally-friendly hydraulic oil	0
Hydraulic oil ISO 46 (cold climates)	0
Cyclone dust separator	0

▶ **CABIN EQUIPMENT**



Foldable Roll-Bar homologated ROPS/FOPS I	0
4 post Canopy homologated ROPS/FOPS I	•
Closed cabin homologate ROPS/FOPS I, pressurized and soundproofed	0
Front and rear windscreen wiper with washer (only for closed cabin)	•
LED work lights (2 front + 2 rear)	•
Document compartment	•
Seat with mechanical suspension	•
Seat with pneumatic suspension	0
Seat with pneumatic suspension and heating	0
Seat armrests	-
Buzzer	•
Cabin carpet	•
Clothes hangers	0
Radio preparation (only for closed cabin)	•
Supplementary socket 12V	•
Manual Air Conditioning	0
„Climatronic Venieri" system	0
Ceiling lamp (only for closed cabin)	•
Sun visor	-
Rear view mirrors	•
Heatable rear view mirrors	0
First-aid kit	0
Fire extinguisher 2kg	0
Seat belt	•
Instrumentation and dashboard with LCD display	•
Safety glass breaker	0

▶ **SPECIAL EQUIPMENT**



Hydraulic quick coupler	0
Cement mixing bucket	0
Multipurpose bucket (4 in 1)	0
Lifting forks	0
Agricultural fork with hydraulic grapple widthh	0
Grab for wrapped bales	0
Bucket with hydraulic grapple	0
Front cutting head	0
Asphalt and cement planer	0
Snow blower	0
Snow blade and "V" type snow blade	0
Angle-tilt dozer blade	0
Hand operating hammer	0
Polishing brush	0
Trencher	0
Auger	0
High tip bucket	0
high flow kit	0
Unpressurized return pipe	0
Double auxiliary line	0
Rear hydraulic line (single effect)	0

STANDARD EQUIPMENTS*



**ANGLE ROLL
SWEPER**



SWEOPER



MIXING BUCKET



4 IN 1 BUCKET



**ANGLE DOZER
BLADE**



SNOW BLADE



BUCKET



GRAPPLE BUCKET



GRAPPLE FORK



GRASS CUTTER



**FRONT
CUTTING HEAD**



**MULTISCREENING
BUCKET**



**LASER ANGLE
DOZER BLADE**



AUGER



SNOW BLOWER



PALLET FORK

* Equipments available on stock; others on request.



Via Piratello, 106 - 48022 Lugo (RA) - ITALY
Tel. +39 0545 904411 Fax +39 0545 30389
e-mail: info@vf-venieri.com | www.vf-venieri.com

Spare Parts

Tel. +39 0545 904429 Fax +39 0545 24555
e-mail: ricambi@vf-venieri.com